



Emergency Response Guide



2018.09
ER27Z0E







TOYOTA MOTOR CORPORATION

Foreword

- This guide provides precautions for emergency responders when handling TOYOTA/LEXUS vehicles during an incident.
- It is important to read this guide thoroughly and understand the structure and features of TOYOTA/LEXUS vehicles to ensure safety.
- The illustrations used in this guide are representative examples. Refer to the Quick Reference Sheet (QRS) for each model for model specific information such as key identification points, component locations, etc.

Reading this manual

■ Explains symbols used in this manual

Symbols	Meanings
 WARNING	■ Explains something that, if not obeyed, could cause death or serious injury to people.
 NOTICE	■ Explains something that, if not obeyed, could cause damage to or a malfunction in the vehicle or its equipment.
 NOTE	■ Explains things not found in the explanations of functions or operation methods, or other convenient-to-know items.
	■ Indicates a description note for components that are subject to unintended deployment, operation, potential explosions or parts that may fly off.
	■ Indicates a description note for components that may cause electric shock.
	■ Indicates a description note for components that may leak.

Foreword**Reading this manual****Components Requiring Special Attention**

• SRS Airbags	8
Driver Airbag	9
Passenger Airbag	10
Front Knee Airbag	10
Front Seat Side Airbag	11
Front Seat Cushion Airbag	11
Curtain Shield Airbag	12
Rear Seat Side Airbag	13
Rear Seat Cushion Airbag	14
Back Window Curtain Shield Airbag	14
• Seatbelt Pretensioner	15
• Pop Up Hood	16
• Gas-filled Damper	17
Front and Rear Suspension Dampers	17
Engine Hood Damper	17
Luggage Compartment, Hatchback Door, Back Door Dampers	18
Performance Damper	18
Tail Gate Damper, Side Gate Damper	19
Seat Damper	20
• 12 V Battery	21
• Sub-battery	22
• High Voltage System	23
High Voltage Battery	26
High Voltage Power Cable	29
Inverter/Converter	29
DC/DC Converter	30
HV/EV/FCV Transmission	
HV/EV/FCV Transaxle	30
Rear Drive Motor	31
A/C Compressor	31
Coolant Heater	32
Plug-in Charging System	32

• Fuel Cell (FC) System	35
FC Stack	37
Hydrogen Tank	38
Hydrogen Pipes	39
Hydrogen Pump	39
FC Water Pump and Hydrogen Pump Inverter	40
FC Boost Converter	40
FC Air Compressor	41
FC Water Pump	41
• CNG Tank	42
• LPG Tank	43
• Urea Selective Catalytic Reduction (SCR) System	44
• High Intensity Discharge (HID) Headlights	45
• Electric Power Steering (EPS)	46
• Solar Powered Ventilation System	47
• Solar Charging System	48
• EC Mirror	50
• Structural Reinforcements	51
Side Impact Protection Beam	51
Ultra High Tensile Strength Sheet	51
• Carbon Fiber Reinforced Plastic (CFRP)	52
• Window Glass	53
Laminated Glass	53
Tempered Glass	53
• Front Seat	54
Manual Seat	54
Power Seat	55
• Rear Seat	57
Manual Seat	57
Power Seat	58
• Headrest	59
Manual Headrest	59
Power Headrest	60
• Active Headrest System	61
• Tilt & Telescopic Steering	62
Manual Tilt & Telescopic	62
Power Tilt & Telescopic	62
• Doors	63
Flush Handle Type	63
Access Door (Double door)	64
Back Door	64

Emergency Response Key Points

• Vehicle Identification	66
Appearance and Logos	66
Frame Number	67
Vehicle Identification Number (VIN)	67
• Immobilize Vehicle	68
Vehicle with High Voltage Battery	70
Vehicle with Hydrogen Gas	70
• Disable Vehicle	72
Vehicle with High Voltage Battery	76
Vehicle with Plug-in Charge System	76
Vehicle with Hydrogen Gas	78
• Stabilize Vehicle	79
• Access Patients	80
Vehicle with High Voltage Battery	80
Vehicle with Hydrogen Gas	81
Cut Vehicle	82
• Fire	83
Fire Extinguisher	83
Vehicle with High Voltage Battery	83
Vehicle with Lithium ion (Li-ion) Battery	83
Vehicle with Urea Solution	84
Vehicle with Hydrogen Gas	84
• Submersion	86
Vehicle with High Voltage Battery	86
• Spills	87
Coolant	87
Lubrication Oil	87
Brake Fluid	87
Power Steering Fluid	87
Window Washer Fluid	87
12 V Battery Electrolyte	87
Sub-battery Electrolyte	88
Vehicle with High Voltage Battery	88
Vehicle with Solar Battery	89
Vehicle with Urea Solution	89
Vehicle with Hydrogen Gas	89
• Gas Leaks	90
Nitrogen (N ₂) Gas	90
Refrigerant Gas	90
Vehicle with CNG	90
Vehicle with LPG	90
Vehicle with Hydrogen Gas	91

Damaged Vehicle Handling Key Points

• Towing Damaged Vehicle	93
Parking Lock	93
Steering Wheel Lock	94
Precautions for FF (Front-engine Front-wheel drive) vehicle	94
Precautions for FR (Front-engine Rear-wheel drive), MR (Mid-engine Rear-wheel drive) and 4WD (Four Wheel Drive) vehicles	94
Vehicle with High Voltage Battery	95
• Storing a Damaged Vehicle	96
Submerged Vehicle	96
Vehicle with High Voltage Battery	96
Vehicle with Hydrogen Gas	97
Vehicle with Sub-battery	97

Components Requiring Special Attention

- The construction and functions of components requiring special attention during emergency response are described in this section.



SRS Airbags

- When a vehicle receives a strong impact that can cause serious injury to the occupants, the SRS airbags deploy and the seatbelts restrain the occupants to help reduce impact to the body. Refer to the QRS for each model for the type and location of each SRS airbag.

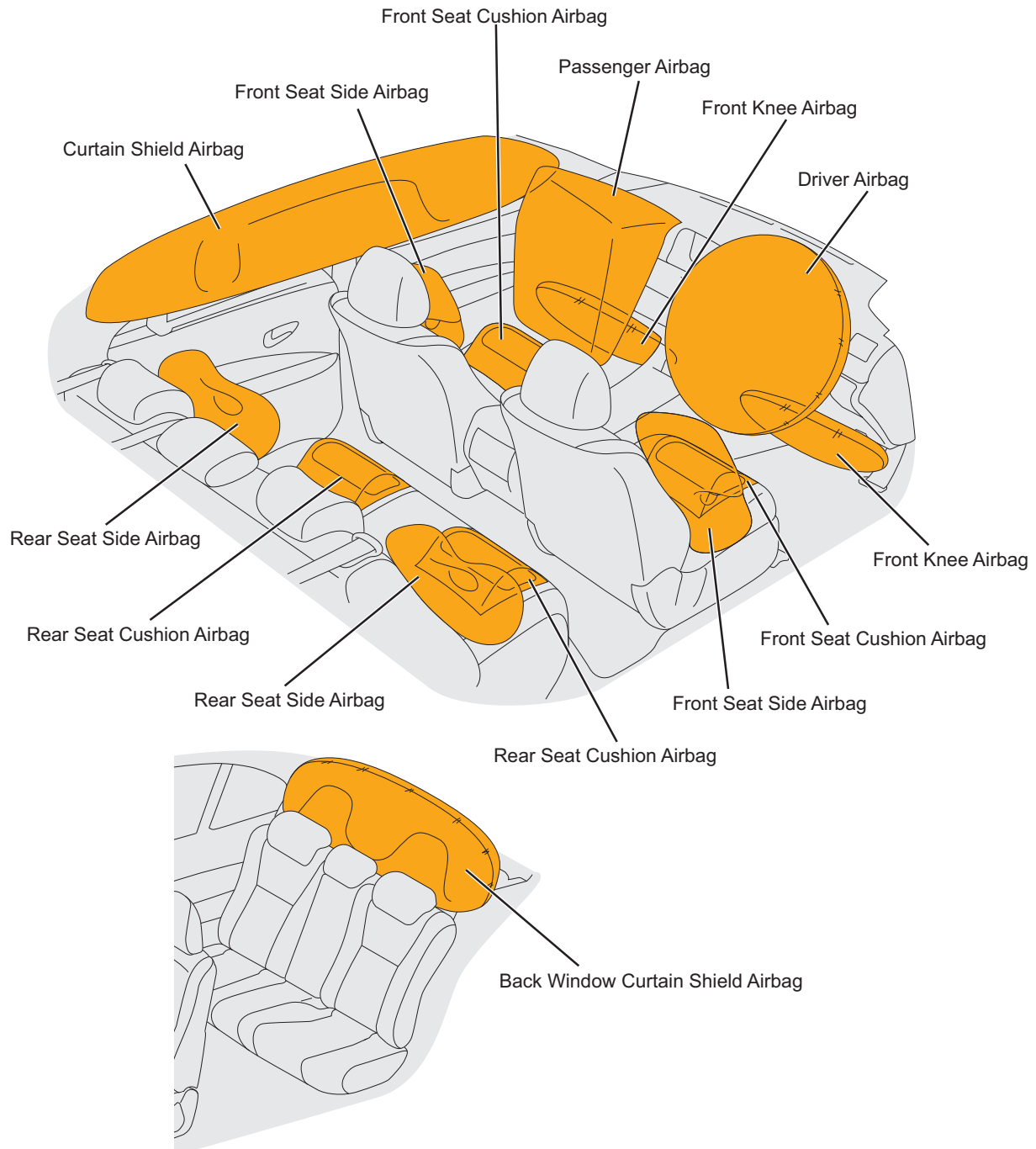

- The SRS airbags consist of an inflator (explosive), a bag and other components and are non-serviceable.
- When an airbag sensor detects a strong impact, an ignition signal is sent to an inflator. When the inflator is ignited, gas is generated to inflate a bag, helping reduce the impact to an occupant.



WARNING

- The SRS airbag may remain powered for up to 90 seconds after the vehicle is shut off and disabled (see page 72). Wait at least 90 seconds before starting any operation. Failure to shut off and disable the vehicle before emergency response procedures are performed may result in serious injury or death from unintentional deployment of the SRS airbag.
- Depending on the circumstances surrounding a collision, such as vehicle speed, point of impact, occupant detection etc., SRS airbags will not always be deployed. If an inflator of the undeployed SRS airbag is breached, the powder inside the inflator may ignite resulting in unintentional SRS airbag deployment. To prevent serious injury or death from unintentional SRS airbag deployment, avoid breaching the inflators.
- Immediately after an SRS airbag is deployed, the components are extremely hot and may cause burns if touched.
- If an SRS airbag deploys with all doors and windows closed, inflation gas may cause breathing difficulty.
- If residue that is produced during SRS airbag deployment comes in contact with skin, rinse it off immediately to prevent skin irritation.

Driver Airbag

- A driver airbag is mounted in the steering wheel pad and activated in the event of a frontal collision.

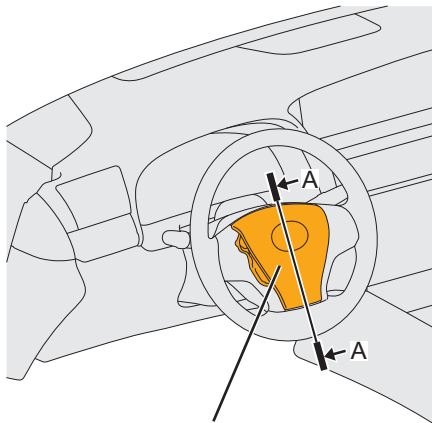

Driver Airbag

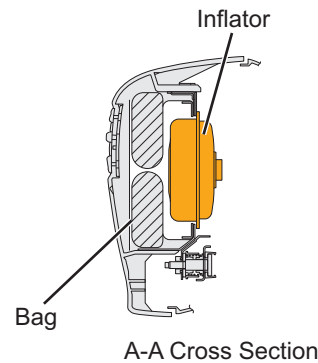

A-A Cross Section



Passenger Airbag

- A passenger airbag is mounted in the upper portion of the passenger side instrument panel and activated in the event of a frontal collision.

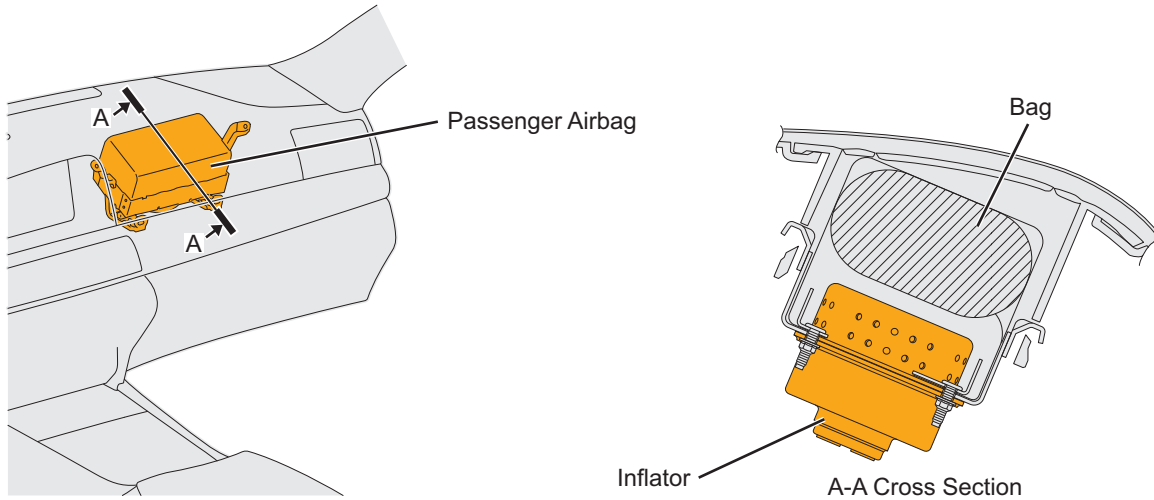

Front Knee Airbag

- Front knee airbags are mounted in the lower portion of the instrument panel on the driver side and the front passenger side, and activated in the event of a frontal collision.

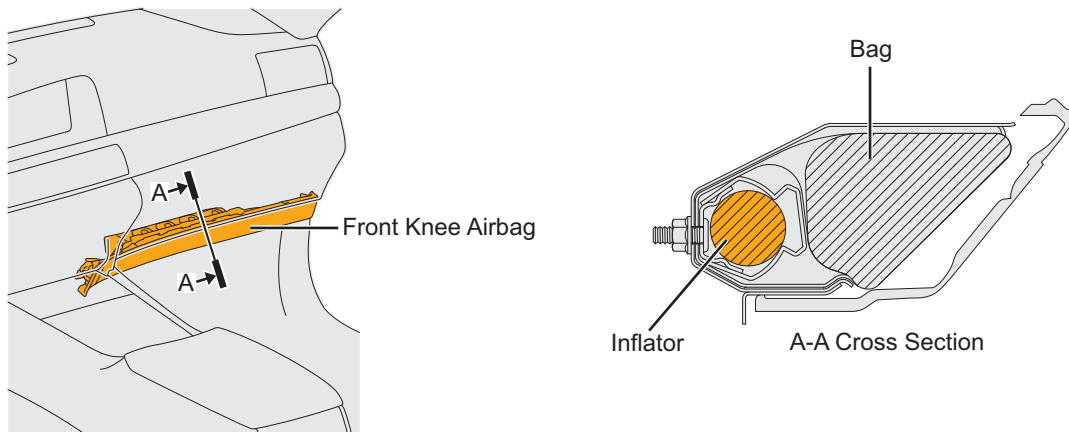



Front Seat Side Airbag

- Front seat side airbags are mounted in the seat frame of the driver seat and the front passenger seat, and activated in the event of a side collision.
- In some vehicles, front seat side airbags are also activated in the event of a frontal collision.

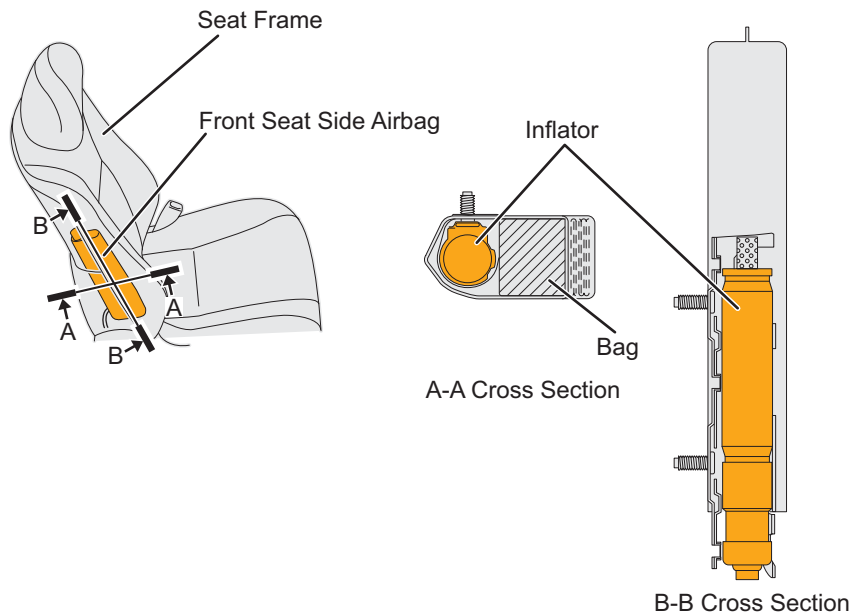

Front Seat Cushion Airbag

- Front seat cushion airbags are mounted in the seat cushion of the driver seat and the front passenger seat, and activated in the event of a frontal collision.

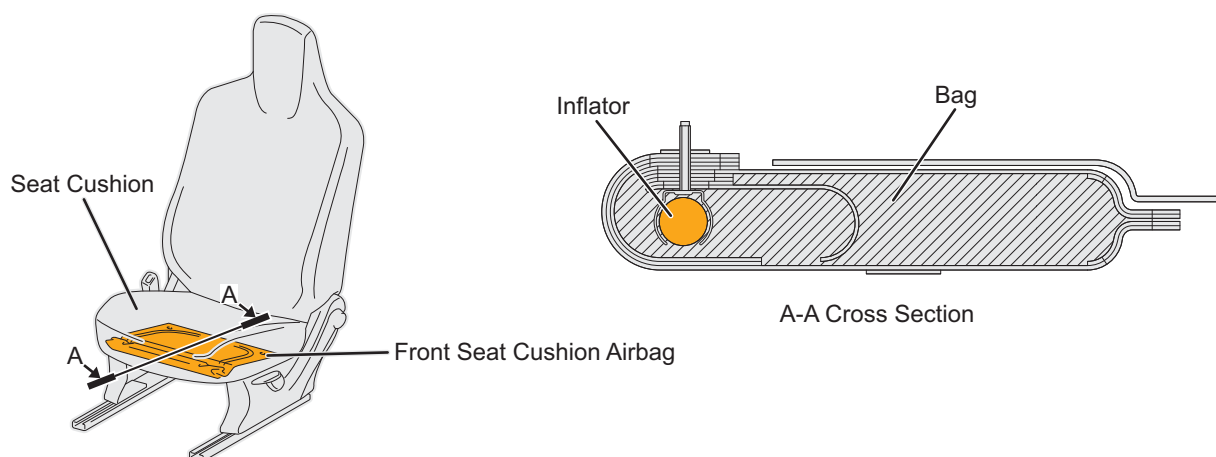



Curtain Shield Airbag

- Curtain shield airbags are mounted in the area between the front pillar and rear pillar on the driver side and the front passenger side, and activated in the event of a side collision.
- In some vehicles, curtain shield airbags are also activated in the event of a frontal collision.

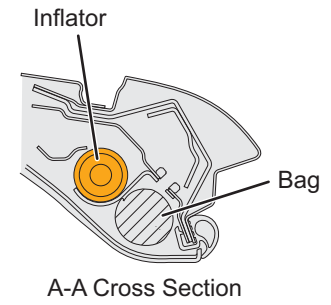
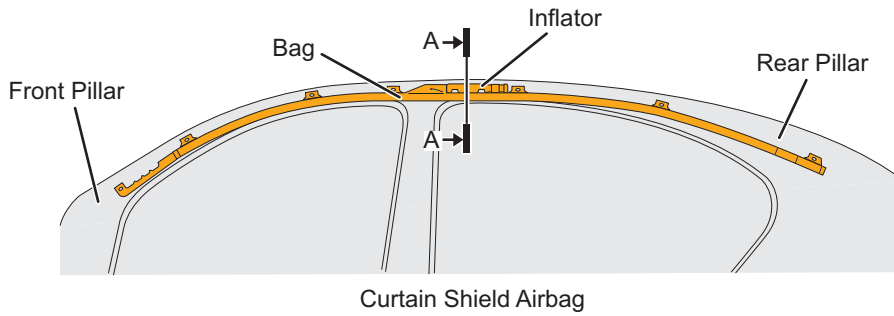



Rear Seat Side Airbag

- Rear seat side airbags are mounted in the sides of the rear seat frame or rear seat side garnish and activated in the event of a side collision.
- In some vehicles, rear seat side airbags are also activated in the event of a frontal collision.

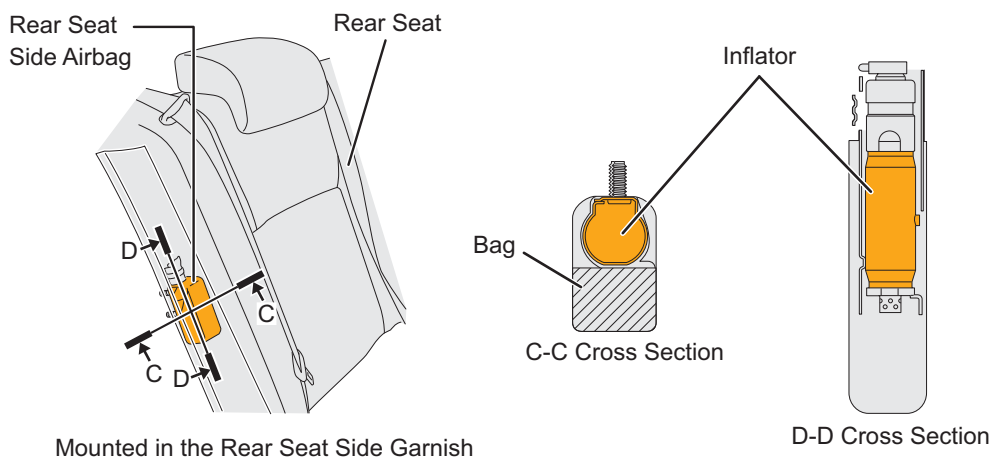
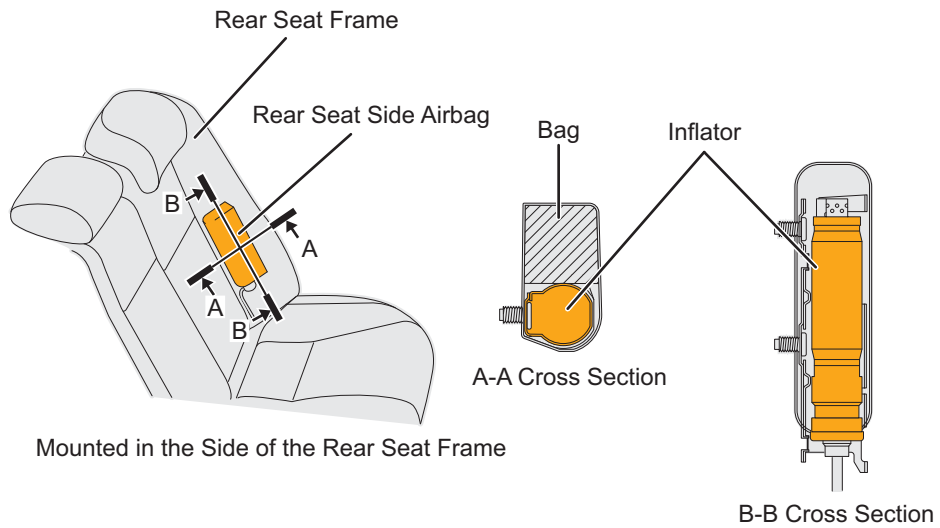



Rear Seat Cushion Airbag

- Rear seat cushion airbags are mounted in the rear seat cushions and activated in the event of a frontal collision.

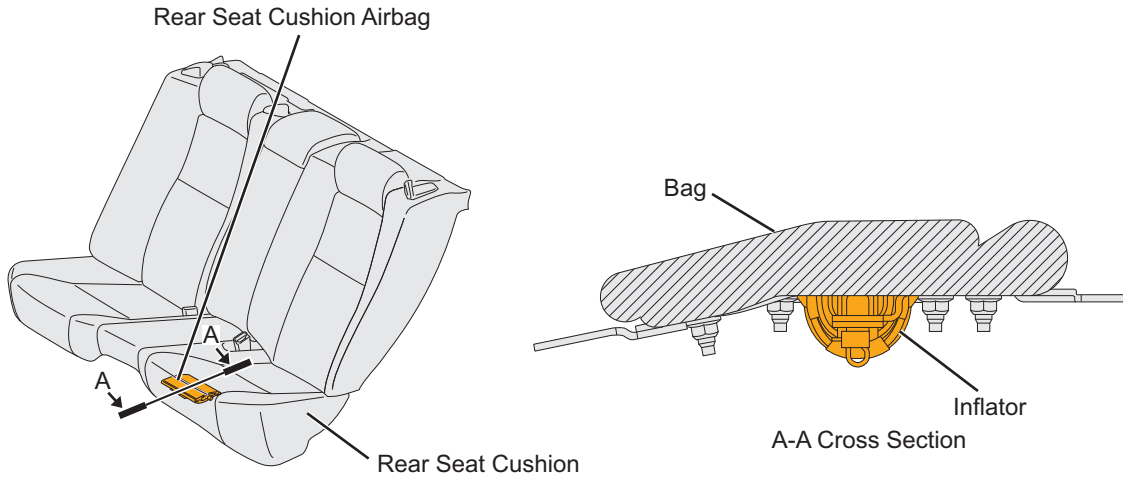

Back Window Curtain Shield Airbag

- A back window curtain shield airbag is mounted in the upper portion of the rear back panel (back door mounting section) and activated in the event of a rear collision.

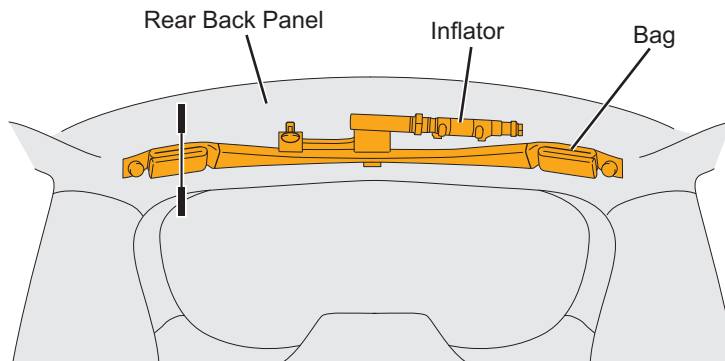

Back Window Curtain Shield Airbag



Seatbelt Pretensioner

- When the vehicle receives a strong impact from the front, the seatbelts are retracted to optimally restrain the occupants.
- In some vehicles, seatbelt pretensioners are also activated in the event of a side collision.

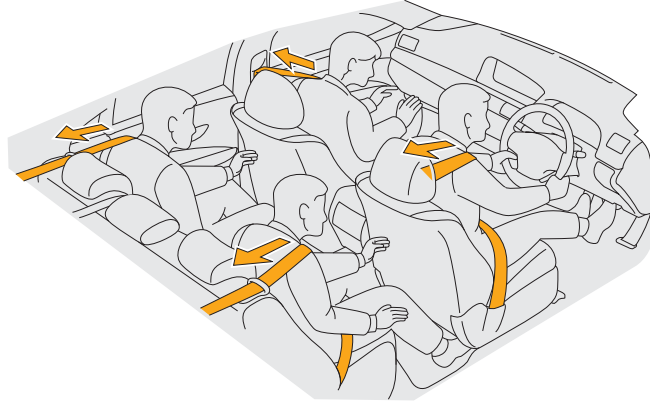

- A pretensioner mechanism is built into the retractor of each of the front seatbelts. Some models have a seatbelt pretensioner mechanism in the rear seatbelts.
- The pretensioner mechanism consists of a gas generator, a piston and a pinion gear.
- When an airbag sensor detects a strong impact, an ignition signal is sent to a gas generator. When the gas generator is ignited, gas is generated and its pressure rotates a gear that retracts the seatbelt.

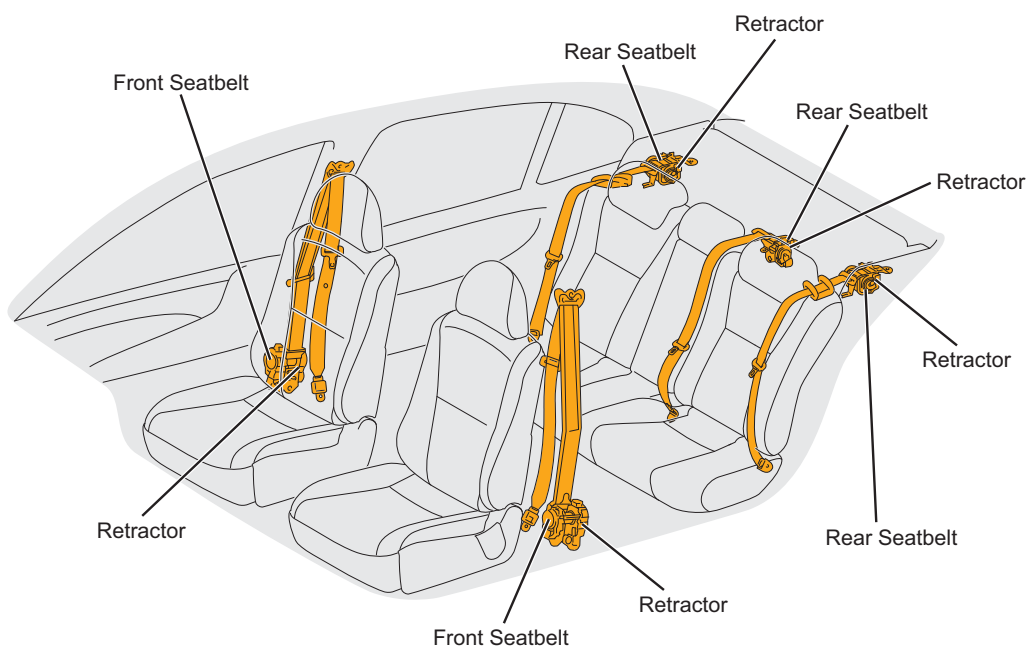

- Refer to the QRS for each model for locations of the seatbelt pretensioners.



WARNING

- The seatbelt pretensioners may remain powered for up to 90 seconds after the vehicle is shut off and disabled (see page 72). Wait at least 90 seconds before starting any operation. Failure to shut off and disable the vehicle before emergency response procedures are performed may result in serious injury or death from unintentional actuation of the seatbelt pretensioner.
- To prevent serious injury or death from unintentional seatbelt pretensioners actuation, avoid breaching the seatbelt pretensioners.



Pop Up Hood

- During a frontal collision, the pop up hood lifts the entire hood or the rear end, ensuring ample space inside the engine room and contributing to reduced collision impact to the head of pedestrians.
- When the sensor inside the front bumper detects a strong impact, an ignition signal is sent to the inflator. When the inflator is ignited, the piston inside the lifter is pushed up, lifting the hood.

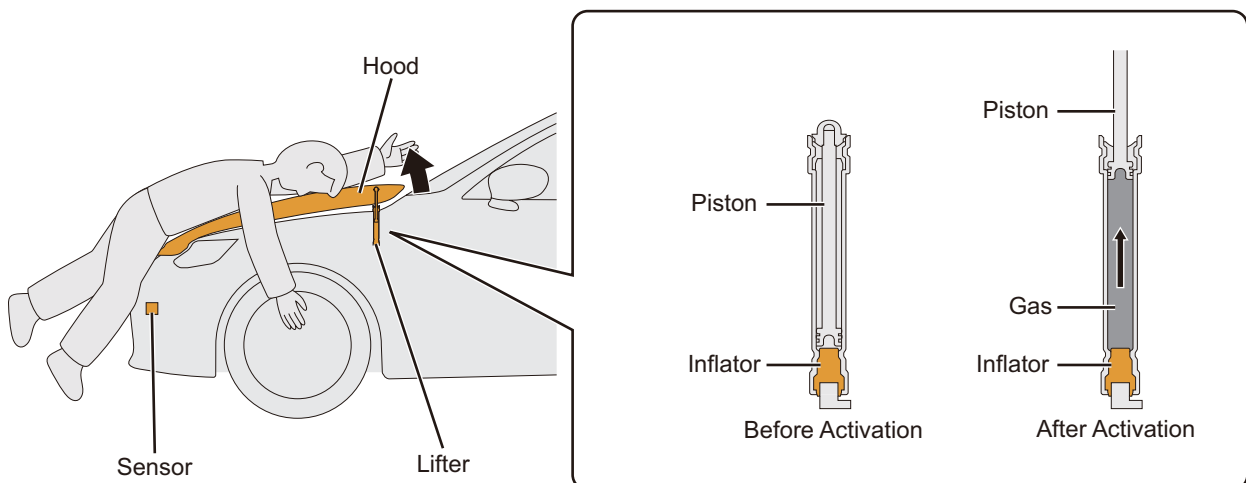
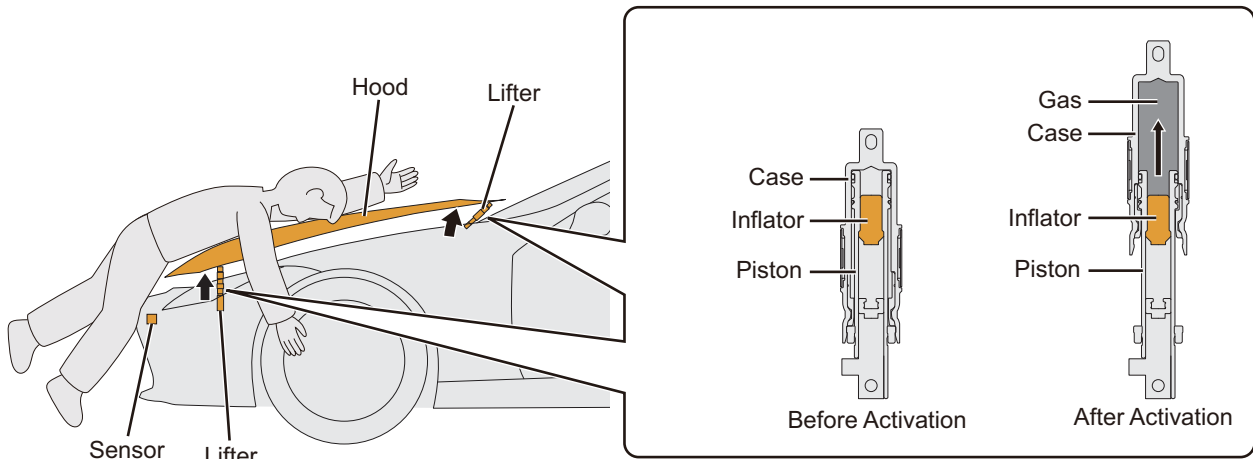

- The pop up hood may remain powered for up to 90 seconds after the vehicle is shut off and disabled (see page 72). Wait at least 90 seconds before starting any operation. Failure to shut off and disable the vehicle before emergency response procedures are performed may result in serious injury or death from unintentional actuation of the pop up hood.
- If a lifter is cut, the pop up hood inflator may unintentionally deploy. To prevent serious injury or death from unintentional pop up hood actuation, avoid breaching the lifters.
- If the hood release lever is pulled after the pop up hood is activated, the hood may rise more, possibly resulting in an injury.
- After the pop up hood is activated, the hood cannot be lowered by hand. If the hood is pushed down excessively, it may be deformed, possibly resulting in an injury.
- Immediately after the pop up hood is activated, the lifters are very hot and may cause burns if touched.



Gas-filled Damper

- Gas-filled dampers are used in various components, such as in the suspension (shock absorbers), engine hood stays, and for other various purposes. Nitrogen (N₂) gas is used in these dampers.
- Nitrogen (N₂) gas is colorless, odorless and harmless.
- Refer to the QRS for each model for the location of these gas-filled dampers.



- If a gas-filled damper is heated in an event of a vehicle fire, the damper may explode due to expanded nitrogen (N₂) gas, possibly causing an injury.
- If a gas-filled damper is cut, nitrogen (N₂) gas may cause metal shavings from the cut to scatter. Wear appropriate safety gear such as safety glasses when cutting a gas-filled damper.

Front and Rear Suspension Dampers

- Suspension dampers are installed in the front and the rear suspension.

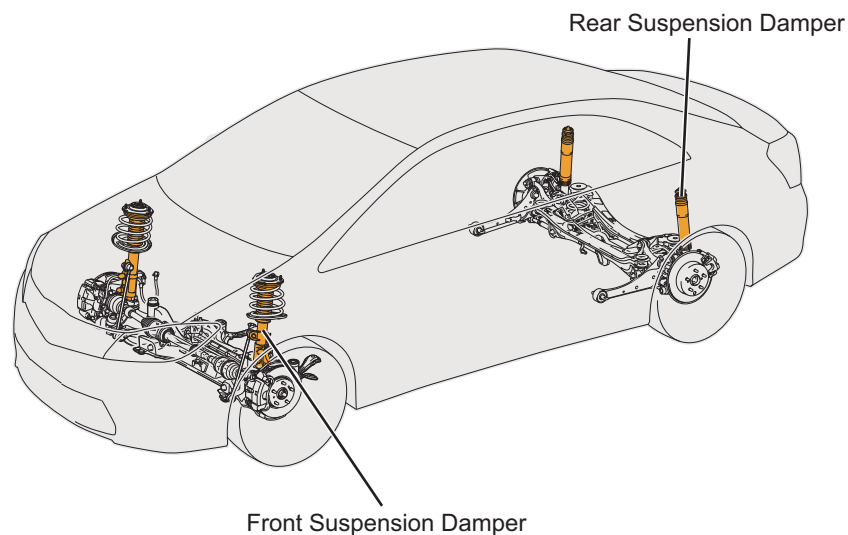

Engine Hood Damper

- Gas-filled dampers are installed as the stays for the engine hood.

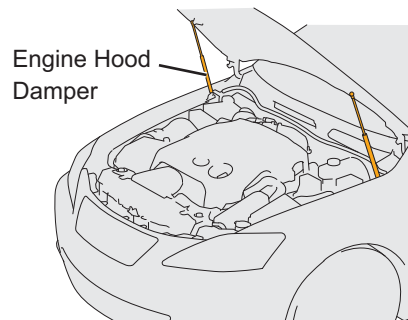



Luggage Compartment, Hatchback Door, Back Door Dampers

- Gas-filled dampers are installed as the stays for the luggage compartment, the hatchback door and the back door.

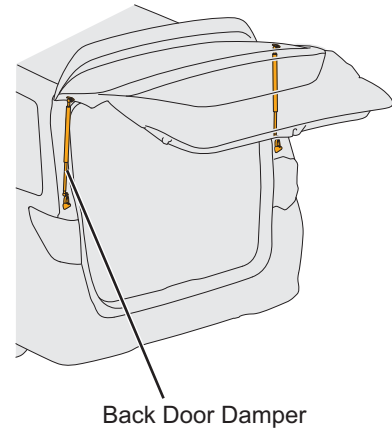
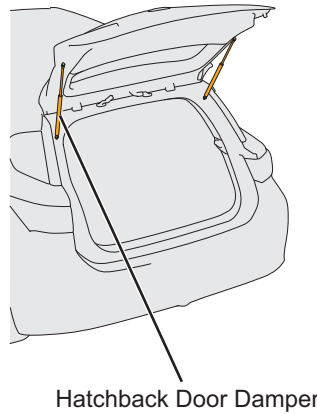
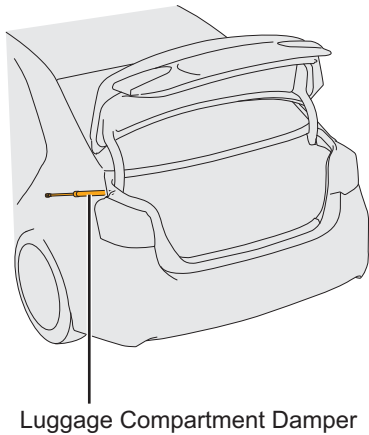

Performance Damper

- Performance dampers are installed across the front and the rear suspension towers and between the right and left sides of the rear lower structural frame (near the rear bumper).

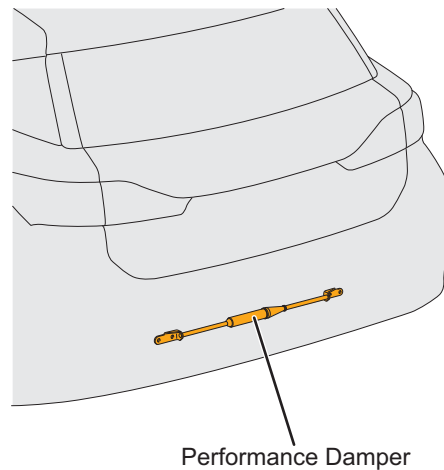
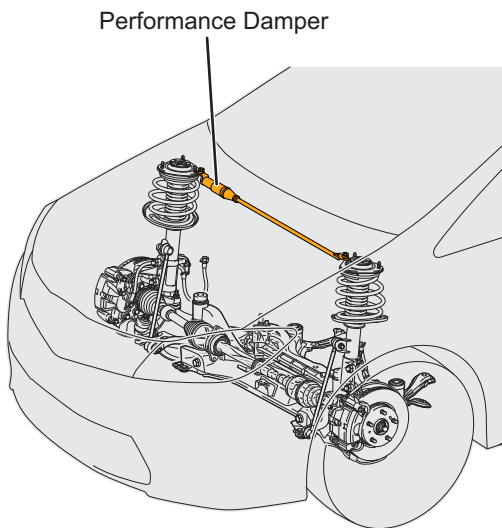



Tail Gate Damper, Side Gate Damper

- Gas-filled dampers are installed as the stays for the tail gate and side gate.

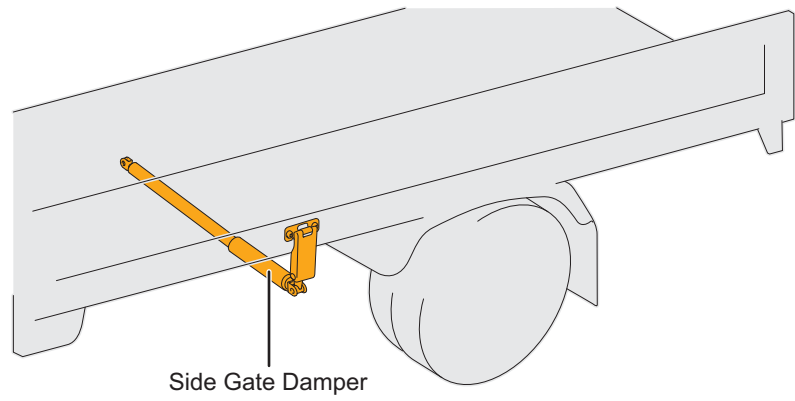
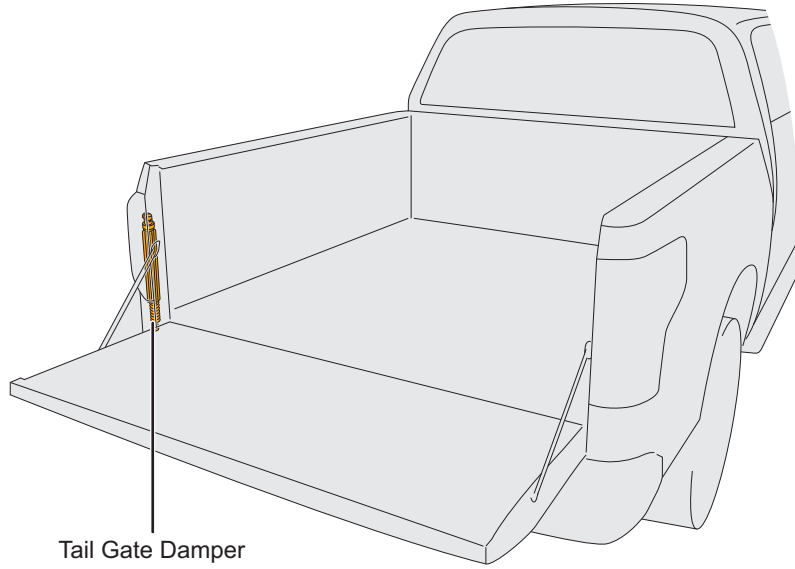



Seat Damper

- Seat dampers are equipped to the lower surface of the seat.

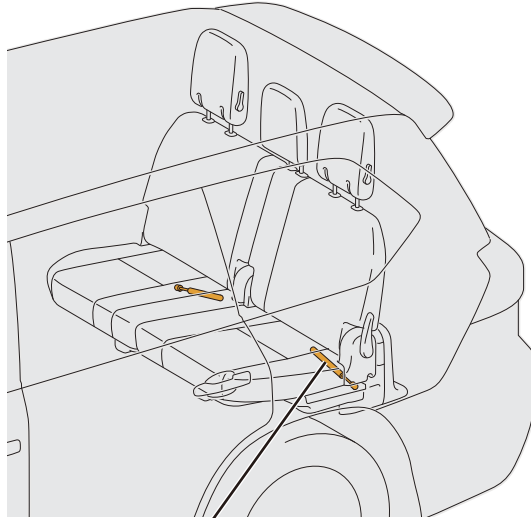

Seat Damper



12 V Battery

- The 12 V battery supplies power to the ECUs that control various systems and auxiliary components such as the power door lock, power window, power tilt and telescopic steering, power seat, etc.
- To ensure safe emergency response operations, it is necessary to completely shut off the vehicle (see page 72). Disconnect the negative battery terminal from the 12 V battery before performing work and shut off the power to the electrical system to prevent electrical fires and to keep the vehicle from starting.
- 12 V battery electrolyte contains dilute sulfuric acid.
- Depending on the model the 12 V battery is installed in the engine compartment, luggage compartment, under the rear seats, etc.
- Refer to the QRS for each model for locations of the 12 V battery.

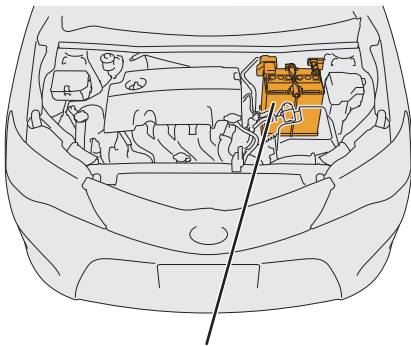

Engine Compartment

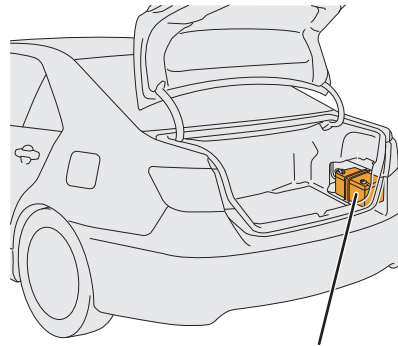

Luggage Compartment

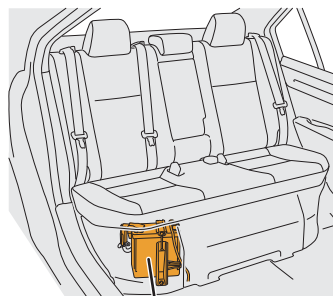

Under Rear Seat



- There is a possibility of explosion due to ignition of the hydrogen gas generated from the 12 V battery. Therefore, do not allow any open sparks or open flames nearby the 12 V battery.
- Dilute sulfuric acid may cause irritation of the skin if contacted. Wear appropriate protective equipment such as rubber gloves and safety goggles when there is a risk of touching electrolyte.



- Once the 12 V battery is disconnected (see page 72), power controls will not operate. To facilitate emergency response operations, lower the windows, open the back door, unlock the doors and take other necessary actions before shutting off the vehicle.
- 12 V battery electrolyte contains ingredients that damage painted surfaces. If any comes in contact with the vehicle body, discoloration or other damage may occur.



Sub-battery

- A sub-battery is installed in vehicles equipped with an electro shiftmatic system and electric parking brake.
- Dual systemization of the 12 V battery power supply enables the parking brake lock operation when the 12 V battery malfunctions.
- By disconnecting the negative (-) terminal of the 12 V battery and shutting of the electricity for 10 minutes or more, the protection relay inside the sub-battery is released and the voltage drops to 0 V.
- 10 nickel-metal hydride automotive batteries are connected in series in the sub-battery, ensuring a 12 V power source.
- A strong alkaline (pH 13.5) potassium hydroxide water solution is used as the sub-battery electrolyte. The electrolyte is soaked into non-woven fabric. However, if the sub-battery is damaged in any way, it may leak.
- Sub-battery is installed in the lower part of the trunk room.

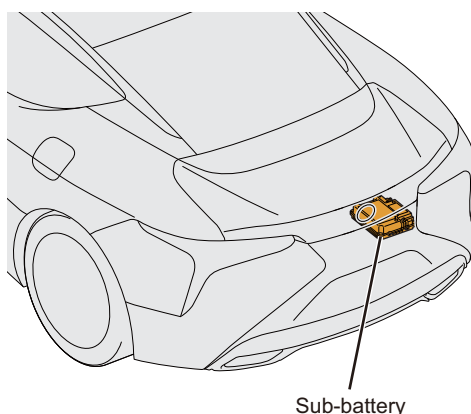

WARNING

- There is a possibility of explosion due to ignition of the hydrogen gas generated from the sub-battery. Therefore, do not allow any open sparks or open flames nearby the sub-battery.
- Strong alkaline (pH 13.5) potassium hydroxide water solution is harmful to the human body. In cases where touching the electrolyte is unavoidable or there is a danger of it being touched, perform work wearing appropriate protective equipment such as rubber gloves and protective glasses.



NOTICE

- After the negative (-) terminal of the 12 V battery has been disconnected and the power has been shut off, approximately 12 V is maintained between the positive (+) terminal and negative (-) terminal of the sub-battery for up to approximately 10 minutes.



High Voltage System

- Hybrid vehicles (HV), plug-in hybrid vehicles (PHV), electric vehicles (EV) and fuel cell vehicles (FCV) use a motor driven by high voltage electricity (over 144 V, up to 650 V) to generate the driving torque. These vehicles are equipped with high voltage electrical components such as a high voltage battery, inverter/converter, transmission/transaxle (electric motor), A/C compressor, charger and voltage inverter as well as high voltage power cables.
- Refer to the Fuel Cell (FC) system (see page 35) for information on the high voltage parts specific to fuel cell vehicles (FCV).
- High voltage electrical components can be indicated by markings on their case/cover. High voltage power cables are indicated by an orange color.
- The cases/covers of the high voltage electrical components are insulated from the high voltage conductors inside the components. The vehicle body is insulated from the high voltage electrical components, and is safe to touch during normal conditions.
- The READY indicator in the combination meter turns on while the high voltage system is operating.

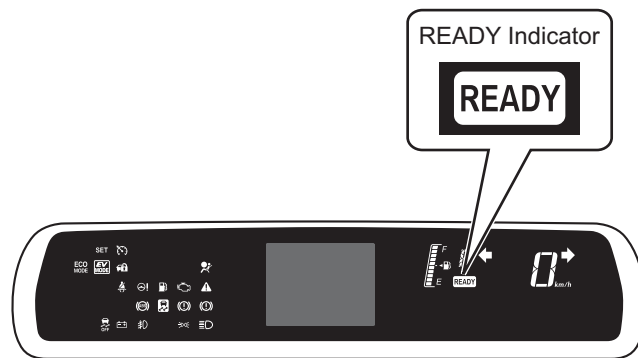
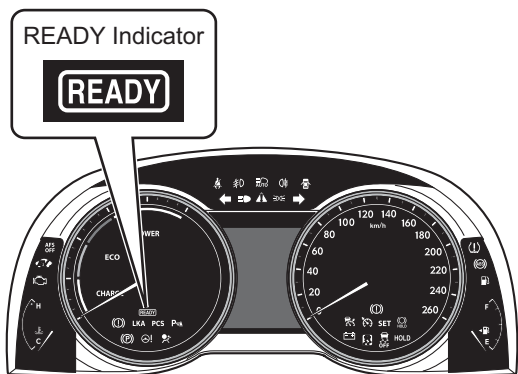

- The high voltage system is deactivated when the ignition switch or power switch is turned OFF. If an impact is detected (SRS airbag is activated) or if a high voltage leakage is detected, the high voltage system is automatically deactivated. When the high voltage is shut off, the READY indicator turns off. However, if the remote air conditioning system or plug-in charging system are being used, even if the READY indicator turns off, the high voltage system may still be active.
- For fuel cell vehicles (FCV), even if the READY indicator turns off, the high voltage system may still be active if the H₂O indicator in the combination meter is illuminated.

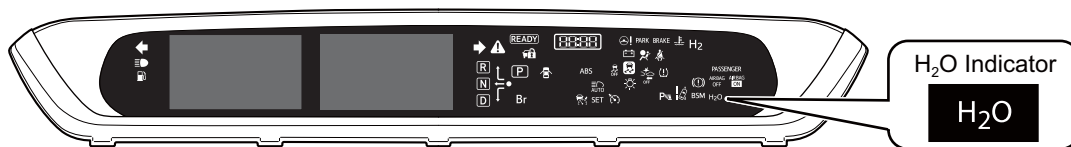

- Refer to the QRS for each model for the locations of the high voltage electrical components.

High Voltage System



WARNING

- The high voltage system may remain charged for up to 10 minutes after the vehicle is shut off and disabled (see page 72). Failure to shut off and disable the vehicle before emergency response procedures are performed may result in serious injury or death from severe burns and electric shock from the high voltage electrical system.
- To prevent serious injury or death from severe burns or electric shock, avoid touching, cutting, or breaching any orange high voltage power cable or high voltage component. Wear appropriate protective equipment such as insulated gloves when there is a risk of touching high voltage power cables or high voltage components.
- When the person(s) in charge of handling the damaged vehicle is away from the vehicle, other person(s) may accidentally touch the vehicle and be electrocuted, resulting in severe injury or death. To avoid this danger, display a “HIGH VOLTAGE DO NOT TOUCH” sign to warn others (print and use page 25 of this guide).



Person in charge: _____

CAUTION:
HIGH-VOLTAGE
DO NOT TOUCH.

CAUTION:
HIGH-VOLTAGE
DO NOT TOUCH.

Person in charge: _____

When performing work on the HV system, fold this sign and put it on the roof of the vehicle.



High Voltage Battery

- The high voltage battery for the motor stores high voltage electricity (144 to 310.8 V). Depending on the model the battery is installed in the luggage compartment, under the rear seats, under the center console or under the floor.

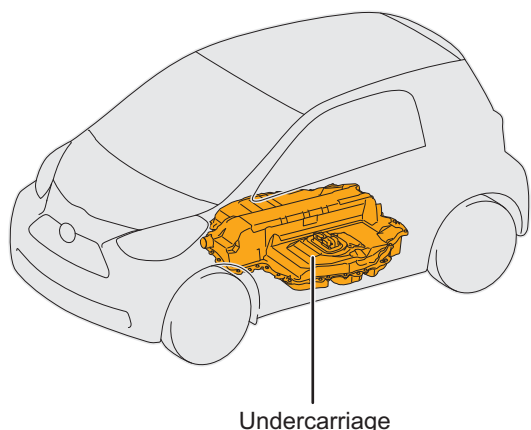
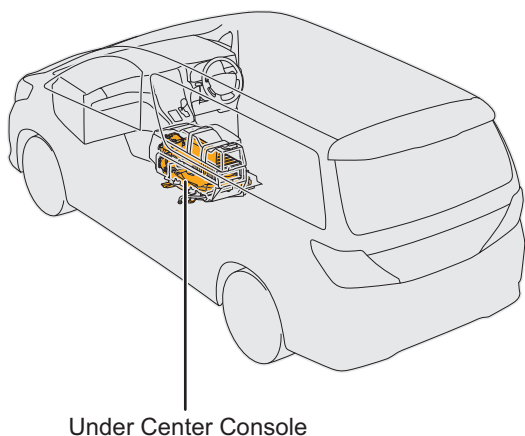
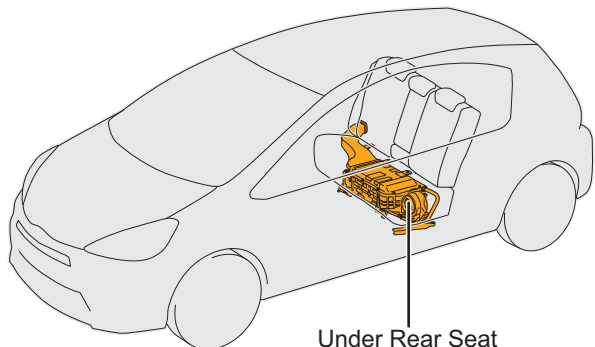
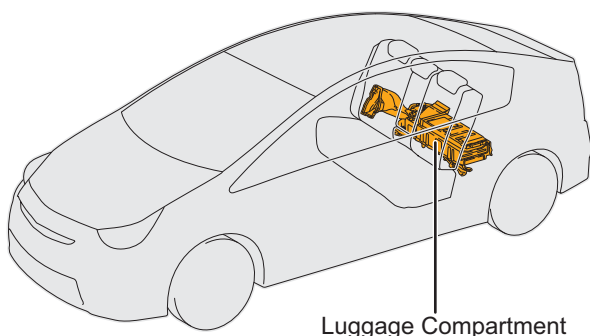

- An under-hood label shows the location of the high voltage battery.

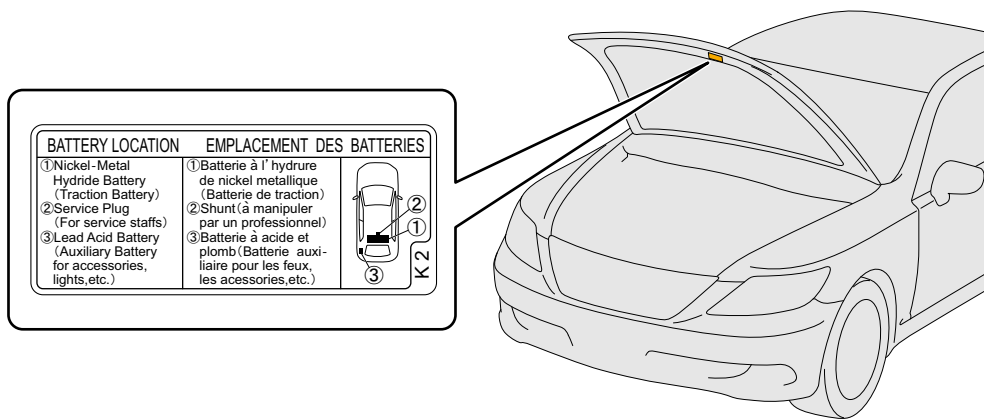



■ A Nickel-metal hydride (Ni-MH) battery or lithium ion (Li-ion) battery is used as the high voltage battery.

1. Nickel-metal hydride (Ni-MH) battery

- Ni-MH batteries consist of 20 to 40 modules, each consisting of six 1.2 V cells, connected in series to obtain high voltage (144 to 288 V).
- The battery modules are contained within a metal case and accessibility is limited.
- A catastrophic crash that would breach both the metal battery pack case and a metal battery module would be a rare occurrence.
- The Ni-MH battery contains a strong alkaline electrolyte (pH 13.5). The electrolyte, however, is absorbed in the cell plates and will not normally spill or leak out even if a battery module is cracked.
- Electrolyte leakage from the HV battery pack is unlikely due to its construction and the amount of available electrolyte contained within the Ni-MH modules. Any spillage would not warrant a declaration as a hazardous material incident.

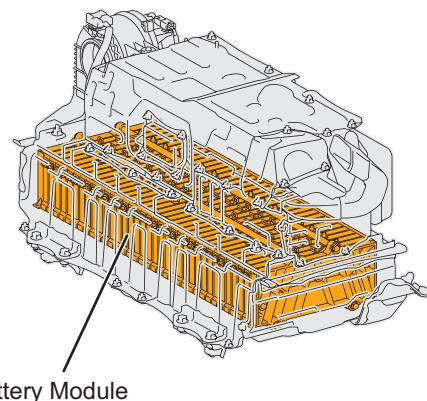
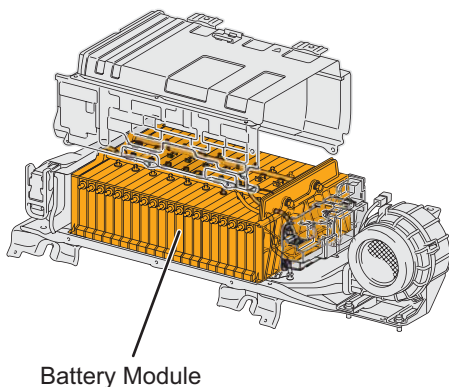

WARNING

- Strong alkaline electrolyte (pH 13.5) is harmful to the human body. To avoid injury by coming in contact with the electrolyte, wear appropriate protective equipment such as rubber gloves and safety goggles when there is a risk of touching electrolyte.



2. Lithium ion (Li-ion) battery

- Li-ion batteries consist of multiple stacks, each stack consisting of 14 to 42 cells. Two to five battery stacks are connected in series to obtain high voltage (201.6 to 351.5 V).
- The battery cells are contained within a case and accessibility is limited.
- A catastrophic crash that would breach both the metal battery stack case or battery frame and a metal battery cells would be a rare occurrence.
- The Li-ion battery electrolyte, mainly consisted of carbonate ester, is a flammable organic electrolyte. The electrolyte is absorbed into the battery cell separators, even if the battery cells are crushed or cracked, it is unlikely that liquid electrolyte will leak.
- Any liquid electrolyte that leaks from a Li-ion battery cell quickly evaporates.

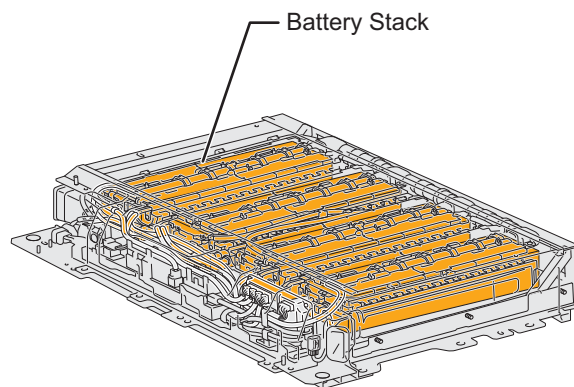
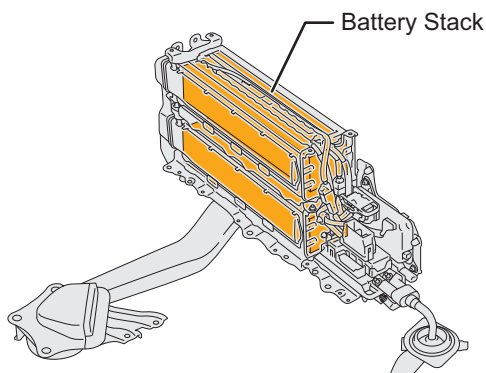

WARNING

- The flammable organic electrolyte which primarily contains carbonate ester is harmful to the human body. In case of contact with the electrolyte, it may irritate the eyes, nose, throat and skin. In case of contact with the smoke or vapor from leaked electrolyte or a burning battery, it may irritate the eyes, nose or throat. To avoid injury by coming in contact with the electrolyte or vapor, wear appropriate protective equipment such as rubber gloves, safety goggles, protective mask or SCBA when there is a risk of touching electrolyte.
- If the electrolyte spills, keep it away from fire and ensure the area is well ventilated. Absorb the electrolyte with a waste cloth or equivalent absorbing material and keep it in an airtight container until disposed of.



High Voltage Power Cable

- High voltage power cables are indicated by an orange color and are used to connect high voltage electrical components such as the high voltage battery inverter/converter, electric motor, A/C compressor and charger.
- The high voltage power cables are installed in the engine/motor compartment and in the center of the vehicle (routed through the center tunnel) or on either side away from the rocker panels.
- Also, high voltage cables are used in the plug-in charging system (see page 32) and the solar charging system (see page 48).

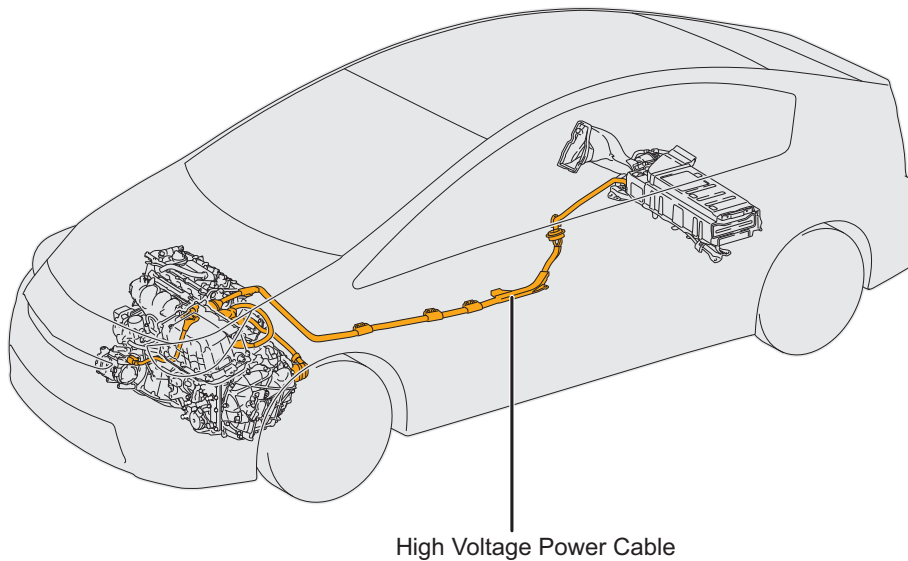

Inverter/Converter

- The inverter/converter installed in the engine/motor compartment boosts and inverts the DC electricity from the high voltage battery to AC electricity that drives the electric motor.
- The inverter/converter of fuel cell vehicles (FCV) also supplies an electric current converted to AC to the FC air compressor.

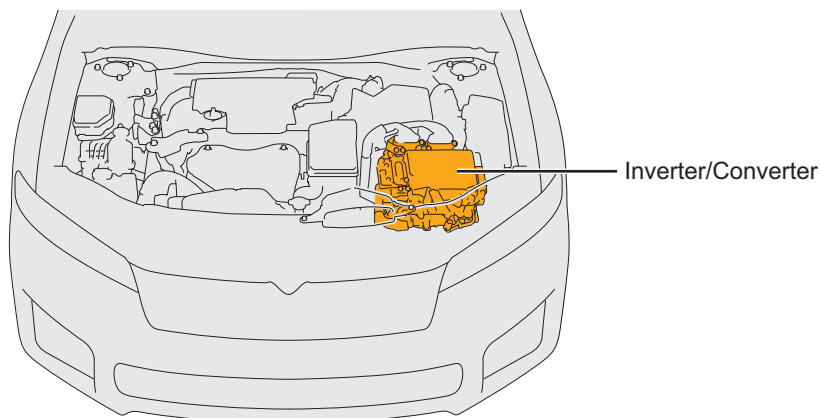



DC/DC Converter

- The DC/DC converter lowers the DC electricity from the high voltage battery to supply it to electric accessories such as the headlights and power windows, and to charge the 12 V battery.
- The DC/DC converter is built into the inverter/converter or installed in the area near the high voltage battery on some models.

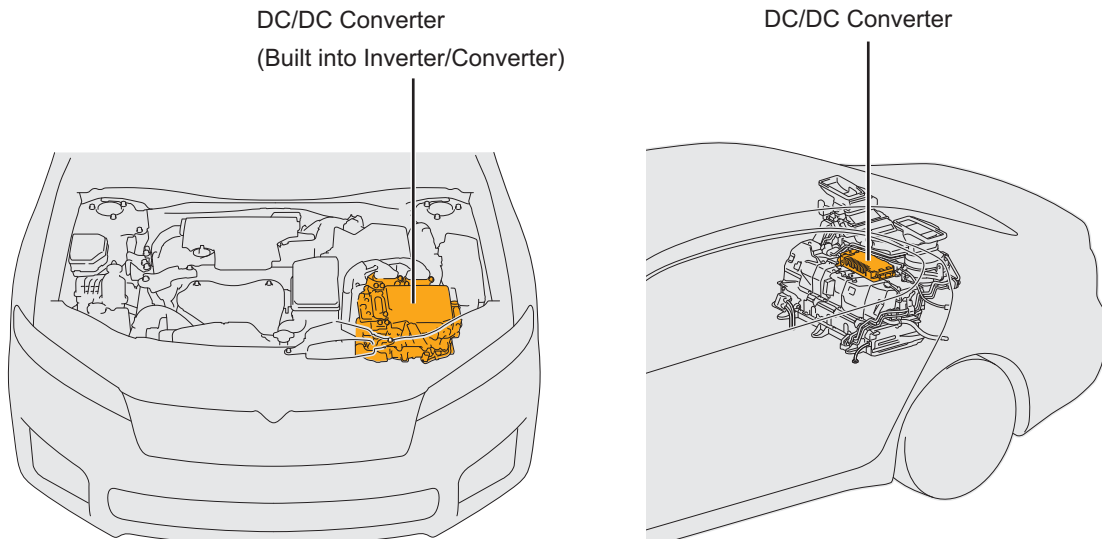

HV/EV/FCV Transmission

HV/EV/FCV Transaxle

- The HV/EV/FCV transmission/transaxle contains an electric motor/generator that is powered by output voltage (up to 650 V) from the inverter/converter, and charges the high voltage battery.
- The HV/EV/FCV transmission/transaxle is installed in the engine compartment or motor compartment. Location varies depending on layout.

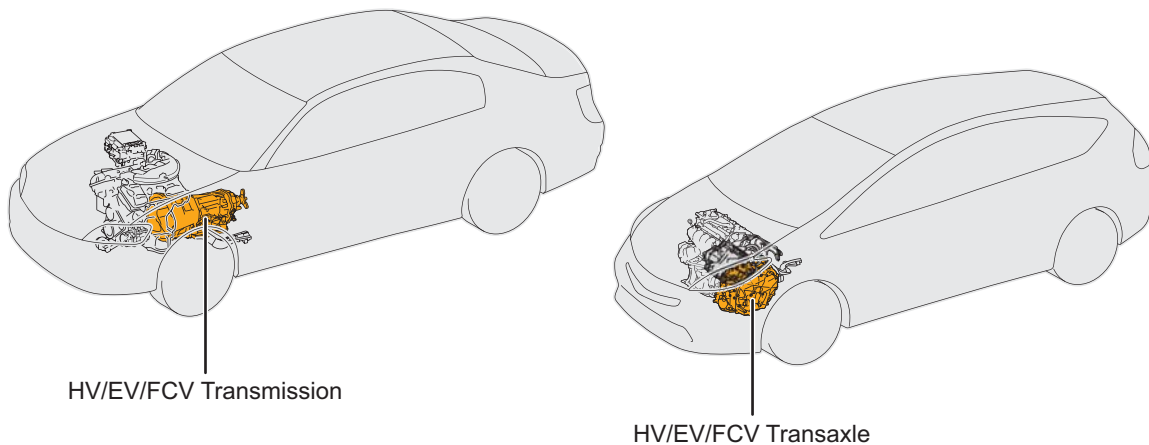



Rear Drive Motor

- The rear drive motor is powered by output voltage (up to 650 V) from the inverter/converter.
- It is built into the rear transaxle and located above the rear driveshafts.

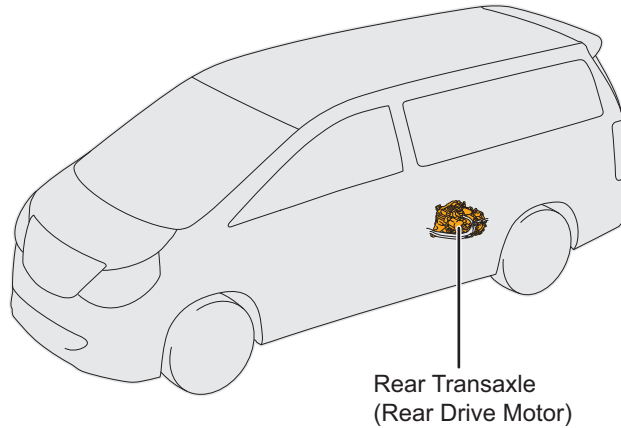

A/C Compressor

- The A/C compressor used on hybrid vehicles (HV), electric vehicles (EV) and fuel cell vehicles (FCV) contains an electric motor that is powered by electricity from the high voltage battery. It is installed in the engine/motor compartment.

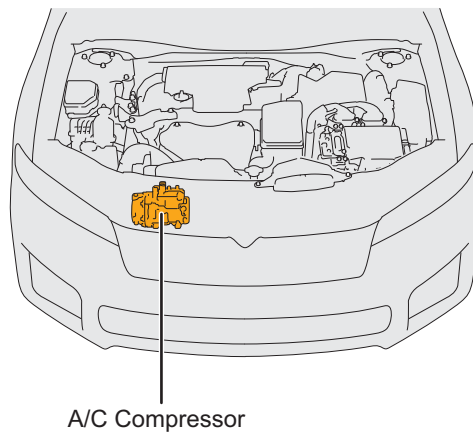



Coolant Heater

- Fuel cell vehicles (FCV) is equipped with a coolant heater to heat the coolant, installed inside the motor compartment.
- The coolant heater is operated using the power from the high voltage battery.

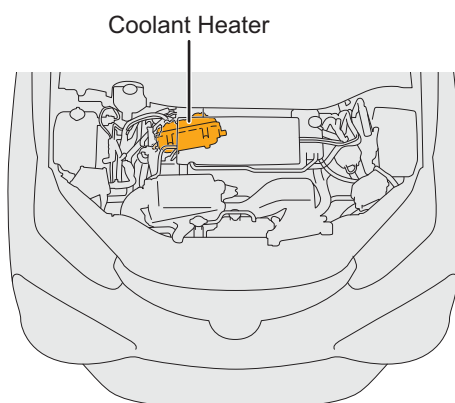

Plug-in Charging System

- Plug-in hybrid vehicles (PHV) and electric vehicles (EV) are equipped with a plug-in charging system in order to charge the high voltage battery from an external power source.
- The plug-in charging system is mainly comprised of an onboard charger and charging inlet.
- The onboard charger converts the AC supplied from an external power source to DC, boosts it, and then uses it to charge the high voltage battery.
- The charger inlet receives the charge to the high voltage battery from an external power source. Also, some electric vehicles have a separate fast charging inlet which can be used at fast chargers (DC 500 V).
- The orange power cables are connected to the charging inlet, which is supplied high voltage during charging.

High Voltage System

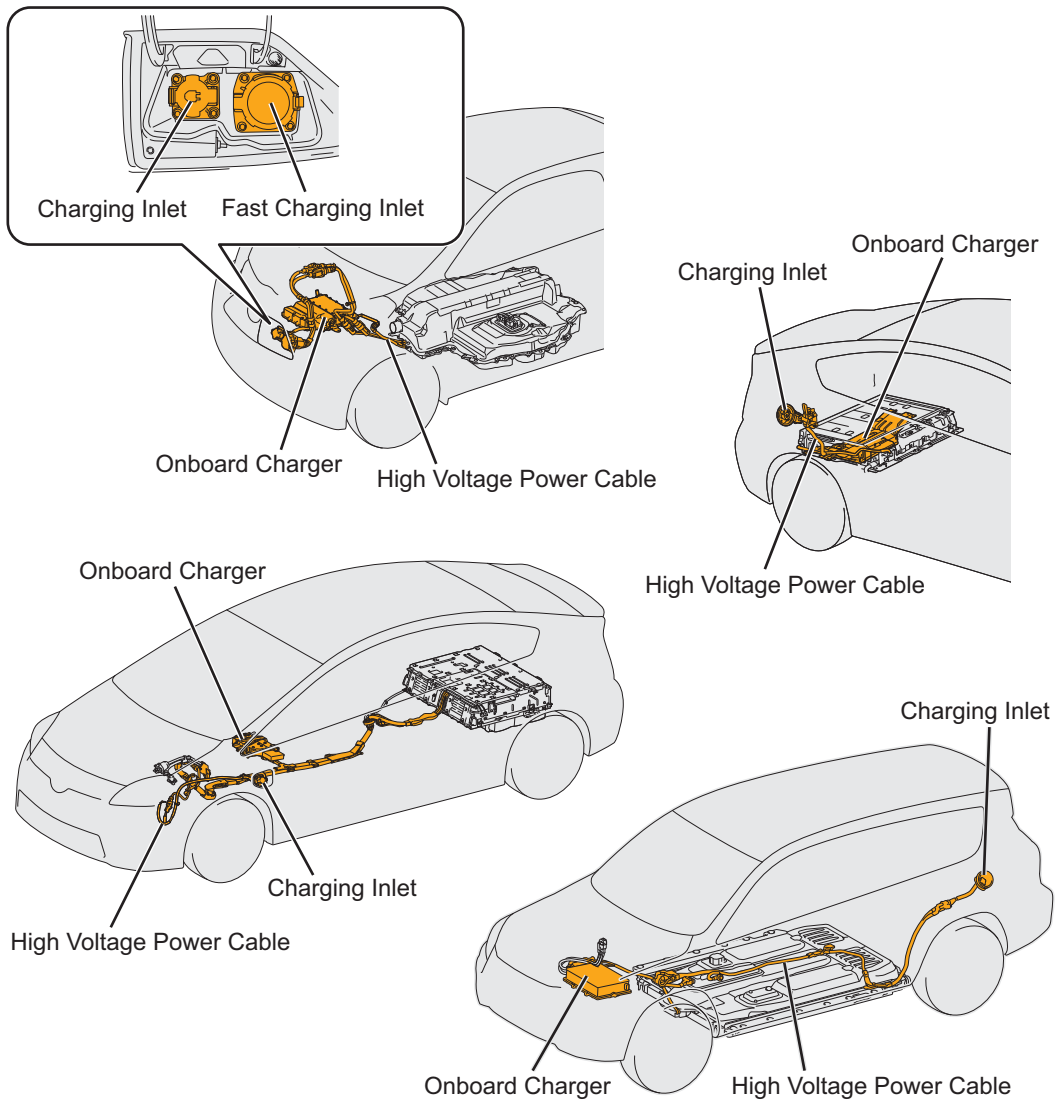

■ To prevent serious injury or death from severe burns or electric shock, shut off the utility circuit supplying power to the charge cable before disconnecting it if the vehicle, charge cable or charger is submerged in water.



NOTICE

- Some plug-in hybrid vehicles and electric vehicles have a connector locking system. The charging connector is unlocked by pressing the charging connector lock switch after unlocking the doors.

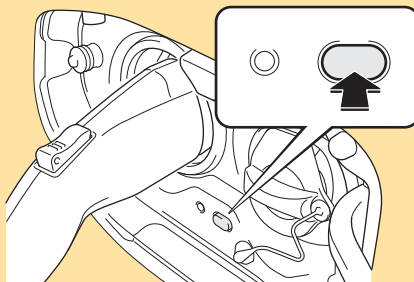

- If the lock of the charge cable assembly connector cannot be released, turn OFF or unplug the external charger, or turn its main breaker OFF.

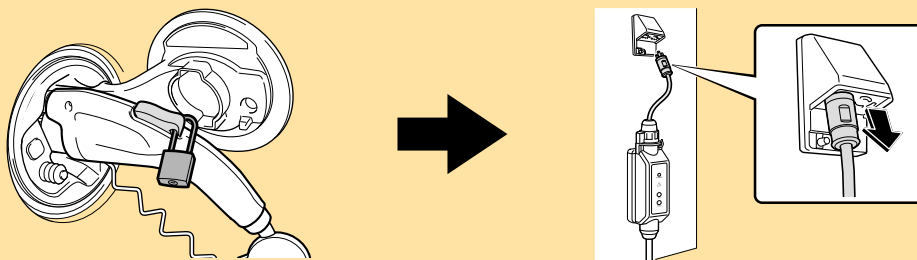

- The lock of the charge cable assembly connector cannot be released during fast charging. If charging does not stop even when the charger is turned OFF, turn its main breaker OFF.



Fuel Cell (FC) System

- Fuel cell vehicles (FCV) use a motor for driving force in the same way as hybrid vehicles. In order to drive the motor, a high voltage (over 200 V, up to 650 V) is used. Not having an engine, the vehicle uses a motor driven by the power generated by a chemical reaction between the hydrogen fuel and oxygen in the air.
- Fuel cell vehicles (FCV) are equipped with dedicated high voltage components such as an FC stack, hydrogen pump, FC water pump, FC water pump and hydrogen pump inverter, FC boost converter and FC air compressor.
- To use hydrogen for power generation, fuel cell vehicles (FCV) are equipped with hydrogen pipes and hydrogen-related parts such as an FC stack, hydrogen tanks, etc.
- The hydrogen tanks are filled with high pressure hydrogen gas (a maximum of 70 MPa (714 kgf/cm², 10,153 psi) at 15°C (59°F)).
- The hydrogen-related parts are inside cases/covers. Also, some of the insulation on high-pressure hydrogen pipes is in red.
- Hydrogen gas is colorless, odorless, and harmless.
- Hydrogen gas is flammable, and can ignite in a wide range of concentrations (4 to 74.5%). However, it diffuses easily and tends not to accumulate, so a small amount of leak would quickly dissipate to a concentration that cannot ignite.
- In case of hydrogen leakage, the hydrogen detector equipped on the vehicle detects the hydrogen leak and shuts off the supply of hydrogen by means of solenoid valves on the tank to prevent a mass leak. Also, hydrogen-related parts are located outside the cabin to allow leaked hydrogen to be easily diffused.
- If a collision is detected, the supply of hydrogen is shut off to prevent a mass leak due to vehicle damage.
- For details about the installation locations of hydrogen-related parts, refer to the QRS (Quick Reference Sheet) for the vehicle.



WARNING

- If the sound of hydrogen leaking (a loud hissing sound) can be heard when working on the vehicle, or if the hydrogen concentration around the vehicle exceeds 4% when measured with a hydrogen concentration detector, immediately step away from the vehicle as there is a chance that the hydrogen gas may ignite.
- Even after the vehicle is stopped (see page 72), hydrogen remains inside the FC stack, hydrogen tanks and other hydrogen-related parts, as well as inside the hydrogen pipe. In order to avoid fires and explosions, never cut or damage these hydrogen-related parts or the hydrogen pipe.
- When the person(s) in charge of handling the damaged vehicle are away from the vehicle and someone else accidentally approaches or touches the vehicle, death or serious injury may occur due to electrocution, a rupture, an explosion or fire. To avoid this danger, display "HIGH VOLTAGE DO NOT TOUCH" and "HIGH-PRESSURE GAS DO NOT TOUCH" signs to warn others (print and use page 25 and 36 of this guide).



Person in charge:

CAUTION:
HIGH-PRESSURE GAS
DO NOT TOUCH.

CAUTION:
HIGH-PRESSURE GAS
DO NOT TOUCH.

Person in charge:



FC Stack

- The FC stack is a device to generate electricity through the chemical reaction between hydrogen and oxygen. Using the hydrogen supplied by the hydrogen tank and oxygen in the air drawn in from outside the vehicle, a high voltage of 200 V or higher is generated.
- The FC stack is installed underneath the floor.
- The FC stack generates power using so called “cells”, which are comprised of an electrolyte membrane sandwiched by separators. A few hundred cells are connected in a row to generate a high voltage.
- The cells are contained inside a metal case so that they are not easily touched.
- Water is generated through the chemical reaction between hydrogen and oxygen during power generation, and discharged via the discharge outlet.

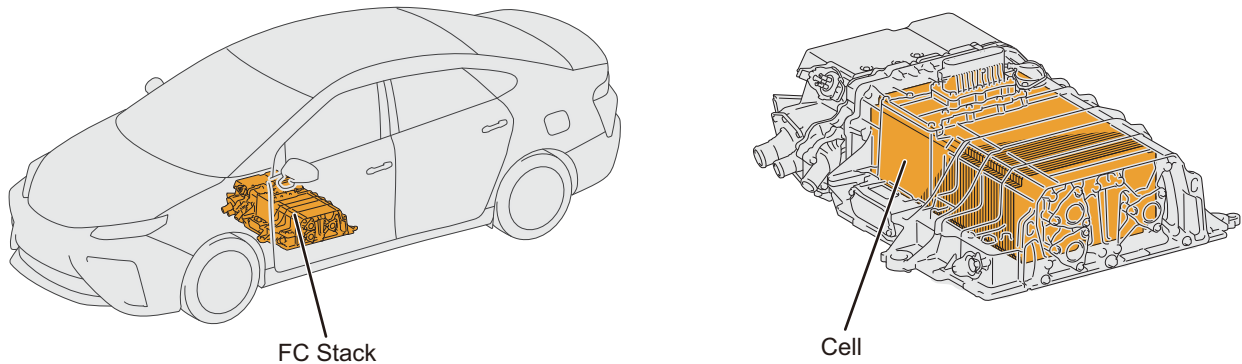

- An under-hood label shows the location of the FC stack.

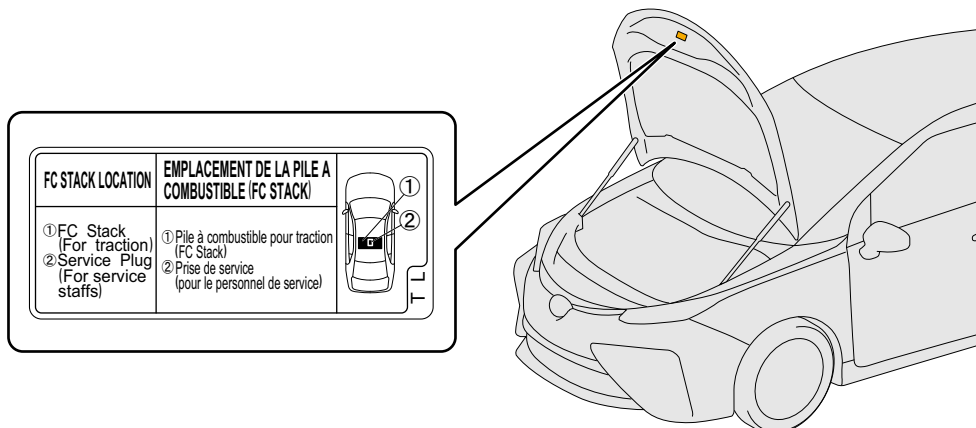



Hydrogen Tank

- The hydrogen tanks are filled with high pressure hydrogen gas (a maximum of 70 MPa (714 kg/cm², 10,153 psi) at 15°C (59°F)) that is supplied to the FC stack.
- The hydrogen tanks are made of carbon fiber-reinforced plastic and located underneath the floor.
- The hydrogen detector used to detect hydrogen leaks is located near the tanks. If a specified concentration of hydrogen leakage is detected, the FC system cuts off the supply of hydrogen.
- Each tank is equipped with a thermal pressure relief device (TPRD) in order to prevent an explosion when the temperature of the hydrogen reaches abnormal levels due to a vehicle fire. The pressure relief device will open at approximately 110°C (230°F) to release the hydrogen gas in the tank outside of the vehicle.

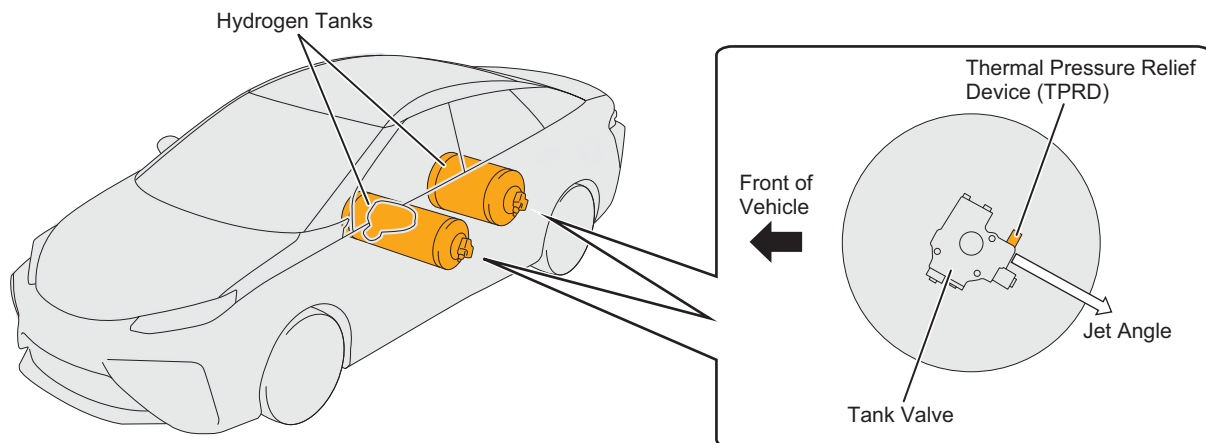

NOTICE

- Depending on the model, multiple hydrogen tanks may be installed. For the detailed installation locations of hydrogen tanks for each model, refer to the Quick Reference Sheet (QRS) for each model.



Hydrogen Pipes

- The hydrogen pipes connect the hydrogen-related parts such as the FC stack and hydrogen tanks.
- The hydrogen pipes are located underneath the floor.
- Some of the high-pressure hydrogen pipes are identified in red.

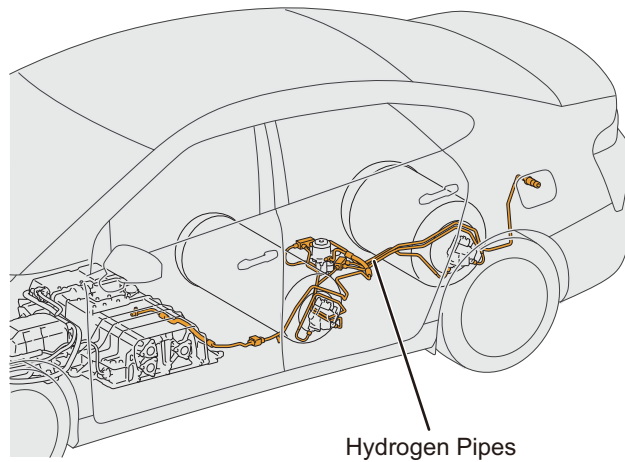

Hydrogen Pump

- The hydrogen pump circulates the hydrogen supplied from the hydrogen tanks into the FC stack.
- The hydrogen pump has a built-in motor that is operated using the high voltage from the FC water pump and hydrogen pump inverter. The hydrogen pump is installed underneath a cover at the side of the FC stack.

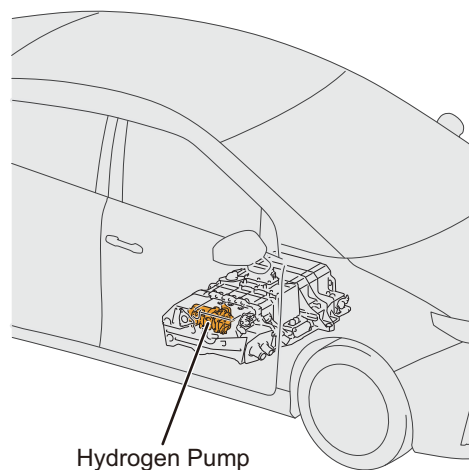



FC Water Pump and Hydrogen Pump Inverter

- The FC water pump and hydrogen pump inverter converts DC from the high voltage battery to AC, and supplies this current to the hydrogen pump and FC water pump.
- The FC water pump and hydrogen pump inverter is installed in the motor compartment.

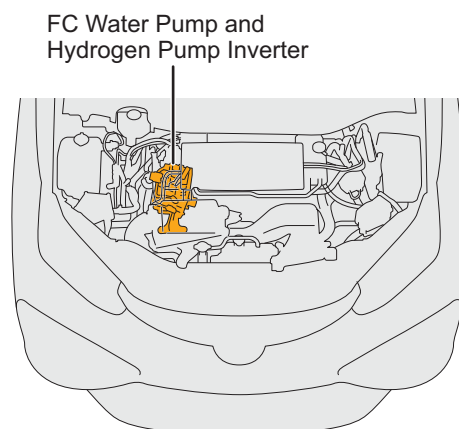

FC Boost Converter

- The FC boost converter increases the voltage of DC generated by the FC stack to a maximum of 650 V for motor operation, and then supplies this current to the inverter/converter.
- The FC boost converter is installed in the center tunnel (outside the cabin).

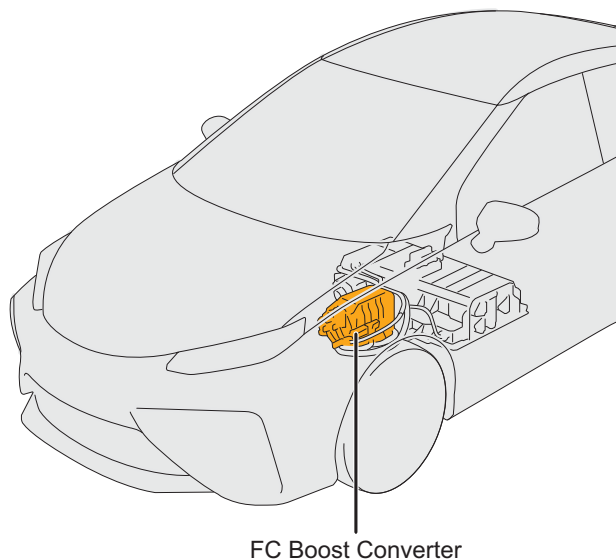



FC Air Compressor

- The FC air compressor supplies air (oxygen) to the FC stack.
- The FC air compressor has a built-in motor which is driven using the output voltage from the inverter/converter (up to 650 V), and is installed in the motor compartment.

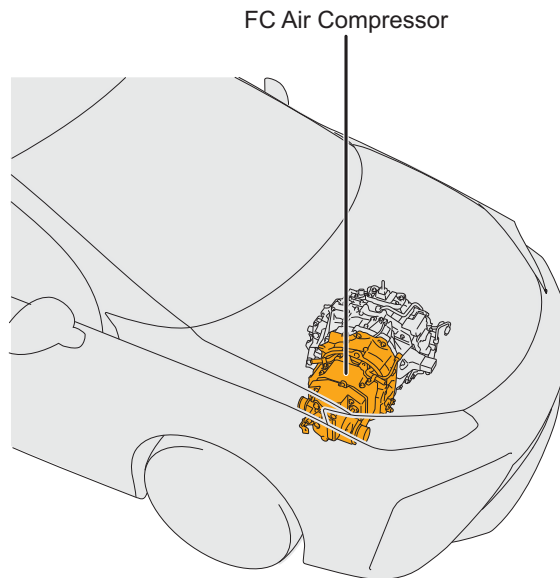

FC Water Pump

- The FC water pump circulates the coolant to cool the FC stack.
- The FC water pump has a built-in motor which is driven using the high voltage from the FC water pump and hydrogen pump inverter, and is installed in the motor compartment.

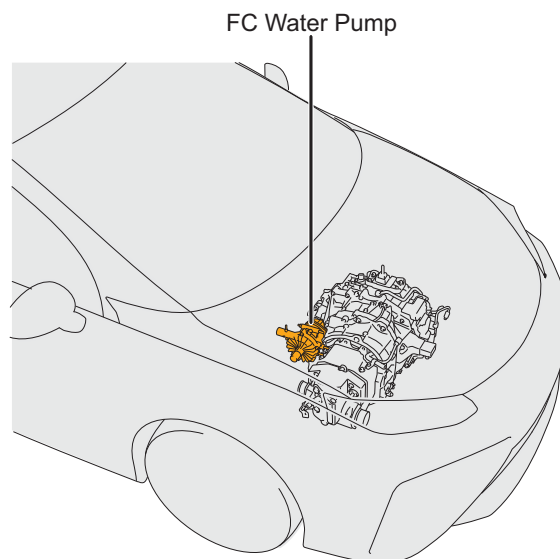



CNG Tank

- The Compressed Natural Gas (CNG) tank is filled with compressed natural gas that is used as fuel for the engine at a maximum pressure of 20 MPa (204 kgf/cm², 2,900 psi).
- The CNG tank is made of metal and located in the luggage compartment, etc.
- The CNG tank is equipped with a pressure relief device (PRD) in order to prevent an explosion when the temperature of the natural gas reaches abnormal levels due to a vehicle fire. The pressure relief device will open at approximately 110°C (230°F) to release the natural gas in the tank outside of the vehicle.
- Natural gas is flammable and can ignite within a concentration of 5.3 to 15.0%.
- Natural gas mainly consists of methane, is harmless and diffuses upwards as it is lighter than air. Also, the gas is infused with a smell so that a leak can be quickly detected.

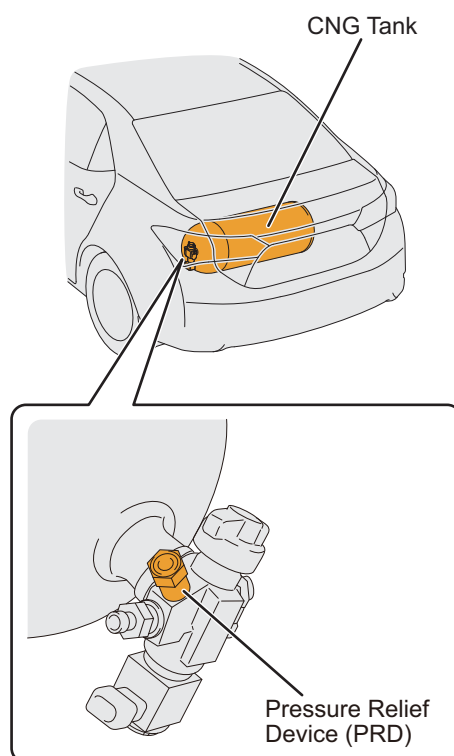

WARNING

- If the sound of natural gas leaking (a loud hissing sound) can be heard when working on the vehicle, or if the smell of natural gas is present, immediately step away from the vehicle as there is a chance that the natural gas may ignite.



LPG Tank

- The Liquefied Petroleum Gas (LPG) tank is filled with compressed liquefied propane, butane, etc. that is used as fuel for the engine at a pressure of 1 MPa (10.2 kgf/cm², 145 psi) or less.
- The LPG tank is made of metal and located in the luggage compartment, etc.
- The LPG tank is equipped with a pressure relief device (PRD) in order to prevent an explosion when the pressure of the LPG reaches abnormal levels due to a vehicle fire. The pressure relief device will open when the pressure in the tank reaches a certain pressure to release the gas in the tank outside the vehicle.
- LPG is flammable and can ignite within a concentration of 2.4 to 9.5%.
- The main components of LPG, propane and butane are harmless and remain close to the ground as they are heavier than air. Also, the gas is infused with a smell so that a leak can be quickly detected.

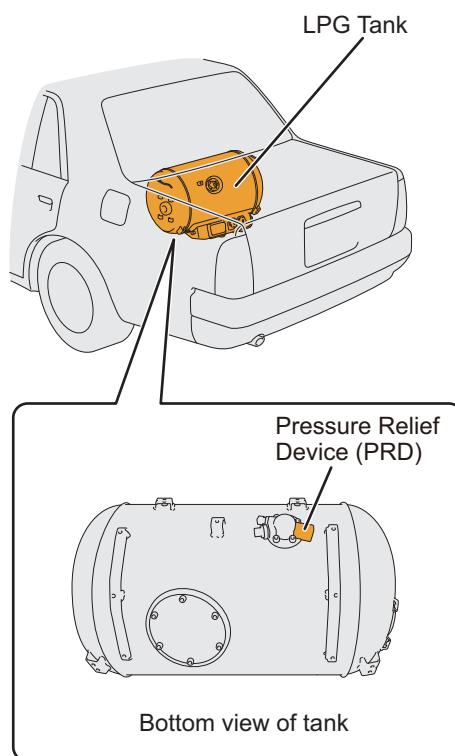

WARNING

- If the sound of LPG leaking (a loud hissing sound) can be heard when working on the vehicle, or if the smell of LPG is present, immediately step away from the vehicle as there is a chance that the LPG may ignite.



Urea Selective Catalytic Reduction (SCR) System

- The urea Selective Catalytic Reduction (SCR) system reduces harmful nitrogen oxides (NOx) in the exhaust gas using a urea solution.
- The urea solution is stored in the urea tank installed below the floor, etc.
- The urea solution is a colorless, odorless and harmless liquid. However, when the temperature is high, such as in the summer, there is a possibility that an irritating odor is produced by the thermolysis of urea solution.
- The urea solution is noncombustible. However, if the urea solution is heated due to a fire, etc., it breaks down and may emit a harmful gas.

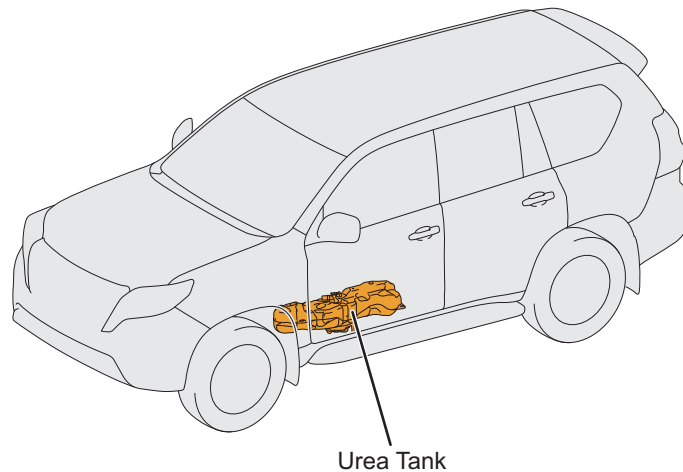

WARNING

- If you come in contact with smoke or vapor from a burning urea tank, it may irritate the eyes, nose or throat. To avoid injury by coming in contact with the smoke or vapor from a burning urea tank, wear appropriate protective equipment such as rubber gloves, safety goggles, a protective mask or SCBA when there is a risk of contacting the smoke or vapor.



High Intensity Discharge (HID) Headlights

- Headlights use High Intensity Discharge (HID) bulbs, which emit light by creating an electric discharge between electrodes inside the bulbs.
- When the HID headlights are turned on, high voltage of approximately 20,000 to 30,000 V is generated instantaneously. During illumination, the voltage from the 12 V battery is boosted to a maximum of 45 V in the electric circuit of the discharge headlights to drive the discharge headlights.

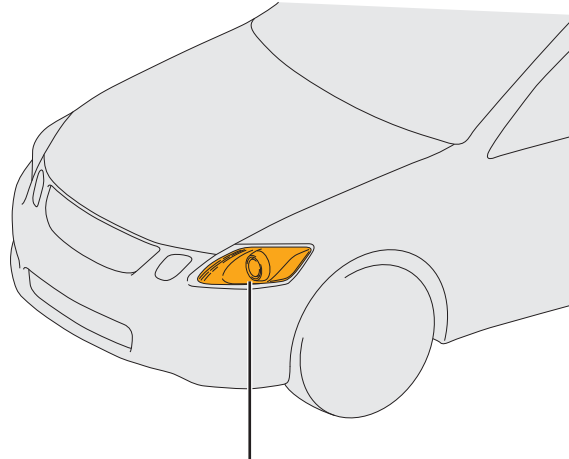

Discharge Headlights



- To prevent serious injury or death from electric shock, avoid touching, cutting, or breaching the bulb, socket, electric circuit and components of the headlights.
- To prevent burns, avoid touching the metal parts on the back of the headlights and the high voltage sockets while the discharge headlights are turned on or immediately after they are turned off.



Electric Power Steering (EPS)

- The Electric Power Steering (EPS) system uses 12 V voltage which has been boosted to up to 46 V by the EPS ECU to drive an EPS assist motor.
- The EPS assist motor is built into the steering gear box or steering column.
- Some hybrid models use voltage from the high voltage battery to drive the EPS assist motor by lowering it to up to 46 V using an EPS the DC/DC converter.
- A wire which conducts up to 46 V connects the EPS ECU in the engine compartment or the instrument panel to the EPS assist motor.

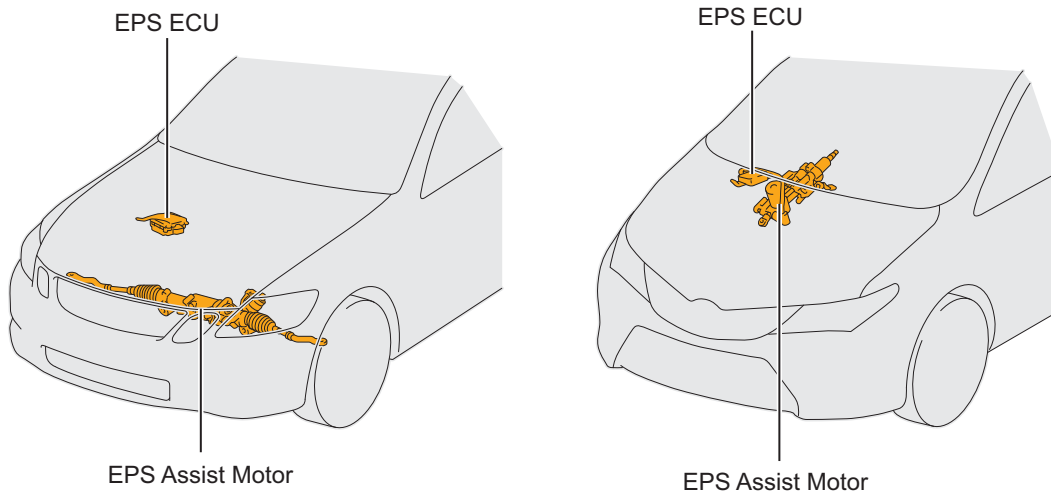

- The Dynamic Rear Steering (DRS) system equipped on some vehicle models uses 12 V voltage which has been boosted to up to 34 V by the DRS ECU to drive the DRS assist motor.

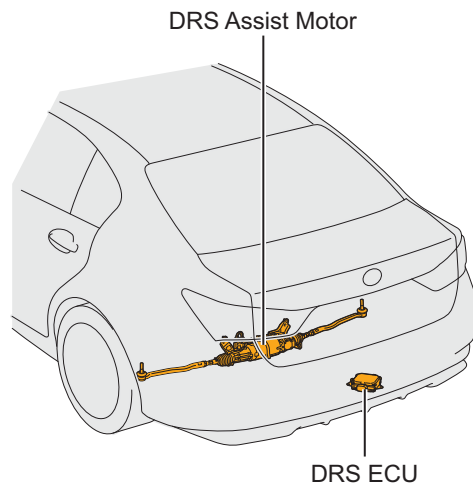



Solar Powered Ventilation System

- The solar powered ventilation system uses solar panels on the vehicle roof to generate up to 27 V of electricity. This electricity is used to power an electric fan which ventilates the cabin while the vehicle is parked in the hot sun.

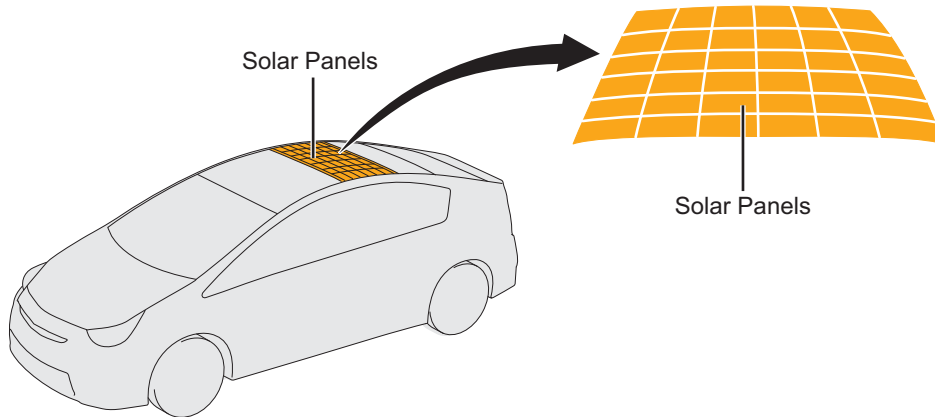

- The solar panels generate electricity with even a small amount of sunlight. To stop generation of electricity, cover the solar panels completely with a material that will block sunlight.



Solar Charging System

- The solar charging system uses a solar roof with an integrated solar cell to generate photovoltaic power which is then used to charge the high voltage battery according to the vehicle condition while parked and to compensate for the consumption of the 12 V battery system while the vehicle is being driven. In addition, the solar charging system charges and discharges the solar battery during this process.
- The solar charging system consists of a solar roof, a solar battery, a solar energy control unit, a high voltage battery and a 12 V battery.
- The orange high voltage power cable is connected between the solar energy control unit and high voltage battery. High voltage is applied when the high voltage battery is charging.
- The solar energy control unit has 3 built-in DC-DC converters: for the high voltage battery, solar battery and auxiliary system.
- An Ni-MH battery is used for the solar battery.
 1. The Ni-MH battery consists of 3 modules, each consisting of six 1.2 V cells, connected in series to obtain 21.6 V.
 2. The Ni-MH battery contains a strong alkaline electrolyte (pH 13.5). The electrolyte, however, is absorbed in the cell plates and will not normally spill or leak out even if a battery module is cracked.
 3. Electrolyte leakage from the solar battery is unlikely due to its construction and the amount of available electrolyte contained within the Ni-MH modules. Any spillage would not warrant a declaration as a hazardous material incident.
- The high voltage battery is not charged except for when the power switch is off.
- Depending on conditions such as solar radiation and temperature, the solar roof can reach a maximum voltage of approximately 50 V.
- Refer to the QRS for each model for the locations of the high voltage electrical components.

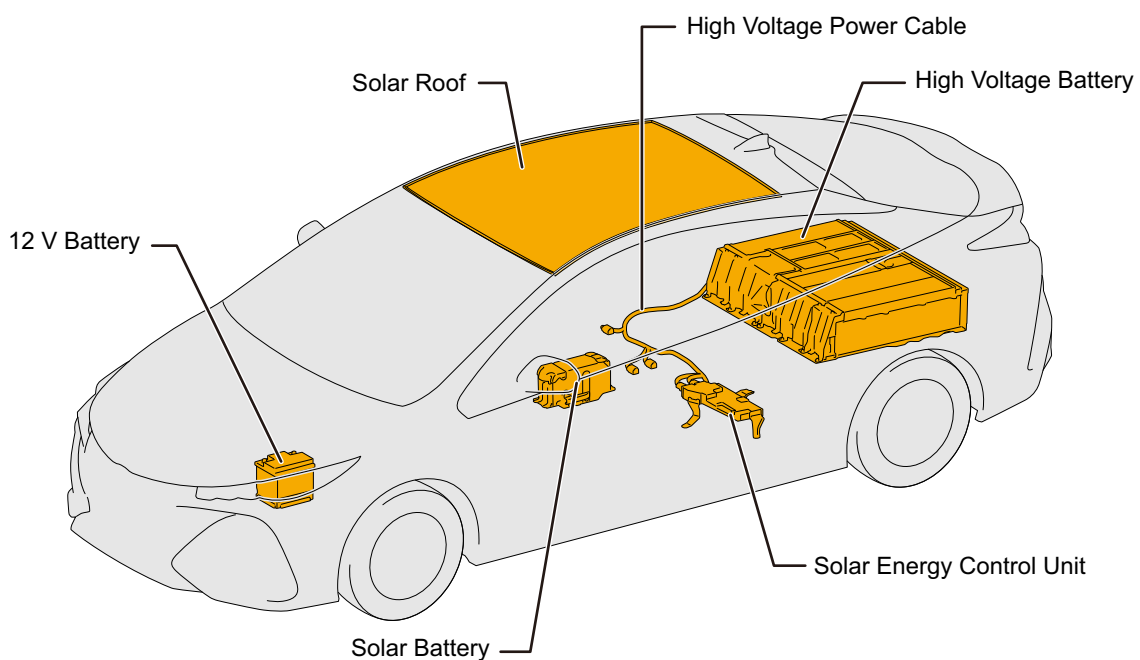

Solar Charging System



WARNING

- The high voltage system may maintain the voltage even when the vehicle is stopped (see page 72) due to the solar charging system. If the high voltage system is not stopped, the high voltage may lead to severe burns or electric shock and may result in death or serious injury.
- To prevent death or serious injury from severe burns or electric shock, avoid touching, cutting, or breaching any orange high voltage power cable or high voltage component. Wear appropriate protective equipment such as insulated gloves when there is a risk of touching high voltage power cables or high voltage components.
- When the person(s) in charge of handling the damaged vehicle is away from the vehicle, other person(s) may accidentally touch the vehicle and be electrocuted, resulting in death or serious injury. To avoid this danger, display a “HIGH VOLTAGE DO NOT TOUCH” sign to warn others (print and use page 25 of this guide).
- The high voltage battery may be charged even when the vehicle is stopped. To stop the high voltage battery from charging, remove the negative (-) terminal of the 12 V battery.
- The solar roof generates electricity with even a small amount of sunlight. To stop generation of electricity, cover the solar roof completely with a material that will block sunlight.
- Strong alkaline electrolyte (pH 13.5) is harmful to the human body. To avoid injury by coming in contact with the electrolyte, wear appropriate protective equipment such as rubber gloves and safety goggles when there is a risk of touching electrolyte.



EC Mirror

- The inner rear view mirror has an auto glare-resistance function, which automatically changes the reflection rate of the mirror. This is done by controlling voltage applied to an electrochromic gel inside the mirror, according to the brightness sensed by a light sensor.

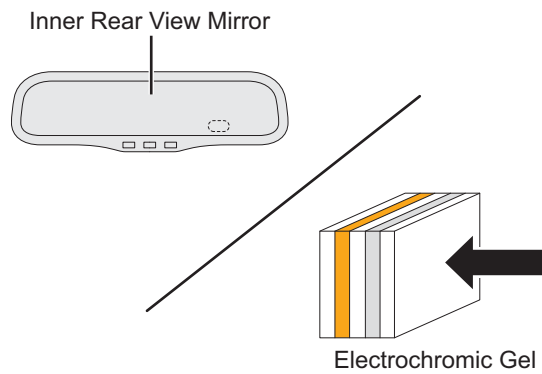

- The electrochromic gel contains organic solvents.



WARNING

- Organic solvents may cause irritation of the skin if contacted. Wear appropriate protective equipment such as rubber gloves and safety goggles when there is a risk of touching electrochromic gel.

Structural Reinforcements

- A side impact protection beam and ultra high tensile strength sheet steel that are stronger than normal steel sheets are used as structural reinforcements.
- Refer to the QRS for each model for locations of the side impact protection beams and ultra high tensile strength sheet steel.



NOTICE

- Because the strength of side impact protection beam and ultra high tensile strength sheet steel is higher than sheet steel and high tensile strength sheet steel, it is difficult to cut through side impact protection beam and ultra high tensile strength sheet steel with conventional cutters. Avoid side impact protection beam and parts made from ultra high tensile strength sheet steel when cutting a vehicle.

Side Impact Protection Beam

- Side impact protection beams are located inside the door.

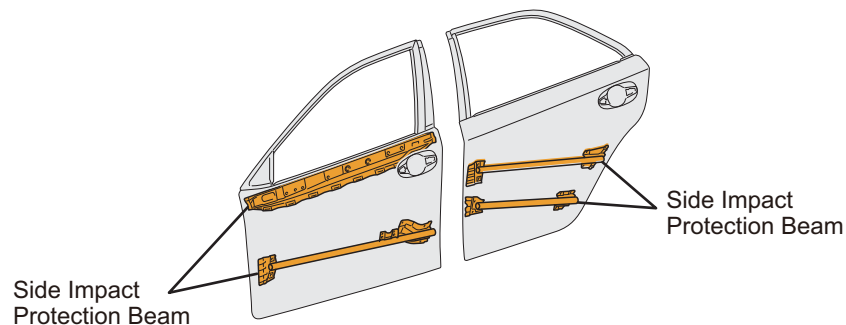

Ultra High Tensile Strength Sheet

- Ultra high tensile strength sheet steel, which is approximately 1.5 times higher strength (1.5 GPa (15,296 kgf/cm², 217,557 psi) class) than standard high tensile strength sheet steel (under 1 GPa (10,197 kgf/cm², 145,038 psi) class), is used for some body structural components on certain models.

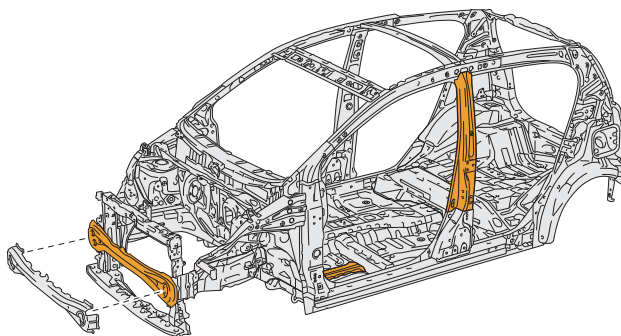

 : Ultra High Tensile Strength Sheet

Carbon Fiber Reinforced Plastic (CFRP)

- Lightweight and highly rigid Carbon Fiber Reinforced Plastic (CFRP) is used for some body structural parts of certain models.
- CFRP can be cut and deformed using cutters for rescue operations.

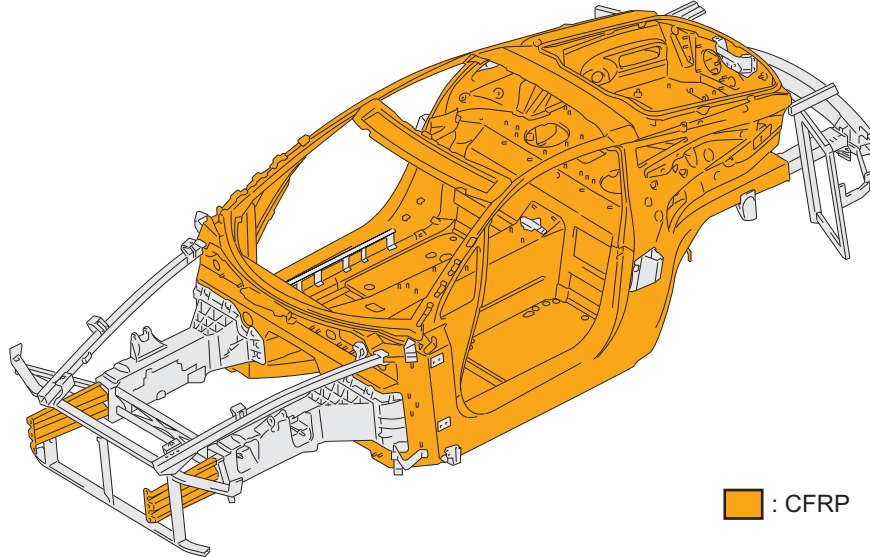

- Cutting CFRP using a grinder or a saw will create carbon fiber dust. Wear appropriate protective equipment such as a dust mask and safety gloves when cutting CFRP.
- CFRP is conductive. If carbon fiber dust attaches to an electrical circuit, a short circuit may result. Keep electrical circuits free from carbon fiber dust when cutting CFRP.

Window Glass

- Laminated glass and tempered glass are widely used for vehicle windows.

* Laminated glass is mainly used for the windshield. It is also used for the door glass on some vehicles.

- Tempered glass is mainly used for the door glass, the roof glass and the back window glass.

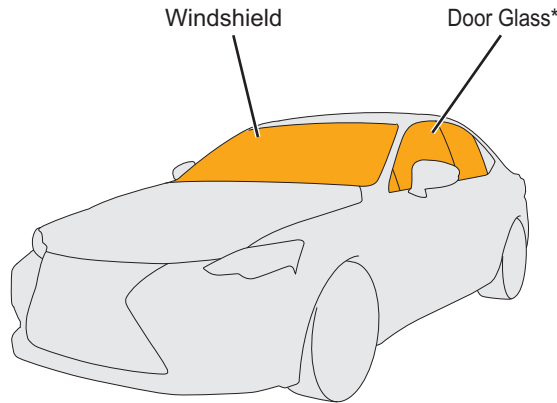

Laminated Glass Applications

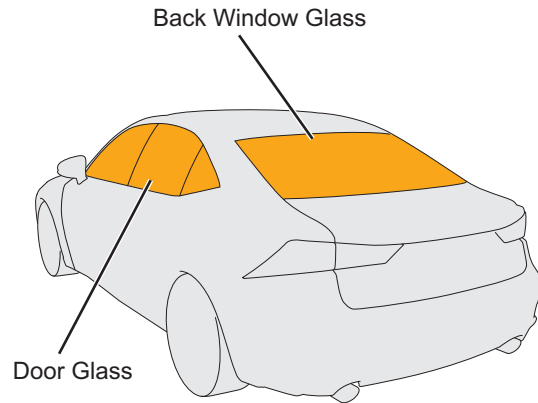

Tempered Glass Applications

- Laminated glass and tempered glass are indicated respectively by “LAMISAFE” or “TEMPERLITE” printed on glass.

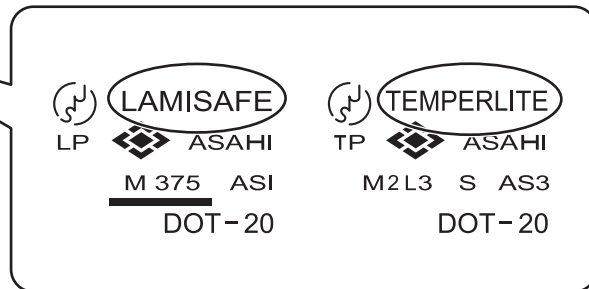
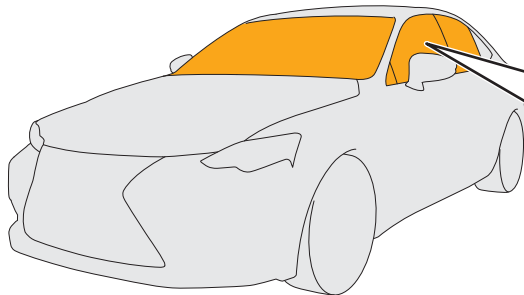

Laminated Glass

- Laminated glass consists of 2 layers of glass with a film in-between. Objects that strike the glass are less like to penetrate the glass and glass shards tend to remain adhered to the film.

< LAMISAFE Structure >

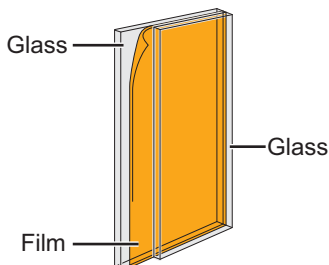

< Broken Laminated Glass >



Tempered Glass

- Tempered glass is heated to near softening temperature, then rapidly cooled down to make it 3 to 5 times stronger than normal glass. When tempered glass is broken, it will break into very small pieces.



NOTICE

- Laminated glass consists of 2 layers of glass bonded together with a film. It does not break easily even when struck by an object.

Front Seat

- Two types of front seats, a manual seat and a power seat, are available. When adjusting the seat position, a lever or a knob is operated for the manual seat and a switch is operated for the power seat.

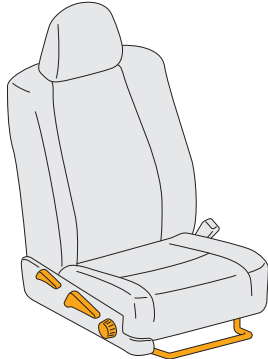

Manual Seat

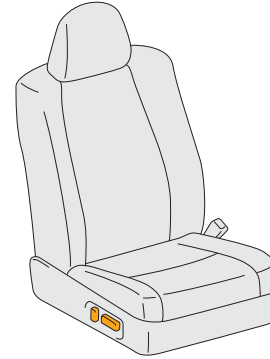

Power Seat

Manual Seat

- The seat can be moved forward/backward by lifting the slide lever (slide adjustment).
- The seatback can be tilted forward/backward by lifting the reclining lever (reclining adjustment).
- The seat cushion can be raised/lowered by repeatedly pulling up/pushing down on the lever (lifter adjustment).
- The front end of the seat cushion can be raised/lowered by turning the vertical knob (front vertical adjustment).

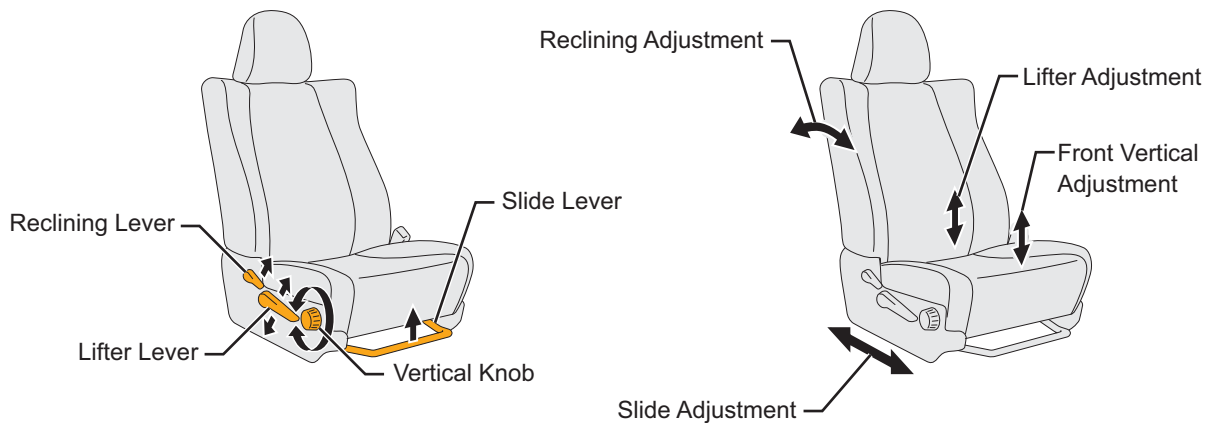

Power Seat

- The seat can be moved forward/backward using the slide function of the power seat switch (slide adjustment).
- The entire seat cushion can be raised/lowered using the lifter function of the power seat switch (lifter adjustment).
- The front end of the seat cushion can be raised/lowered using the front vertical function of the power seat switch (front vertical adjustment).
- The seatback can be tilted forward/backward by operating the reclining adjustment switch (reclining adjustment).
- The lumbar support position can be moved forward/backward by operating the lumbar support adjustment switch (lumbar support adjustment).
- The side support position can be moved right/left by operating the side support position adjustment switch (side support adjustment).
- The pelvic support position can be moved forward/backward by operating the pelvic support position adjustment switch (pelvic support adjustment).
- The shoulder support position can be moved forward/backward by operating the shoulder support position adjustment switch (shoulder support adjustment).
- The length of the seat cushion can be adjusted by operating the cushion length adjustment switch (cushion length adjustment).

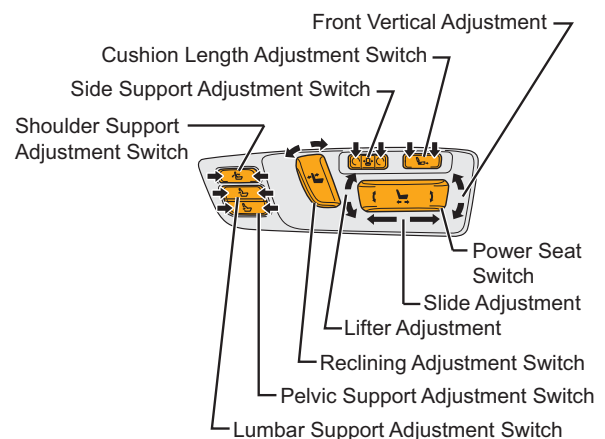
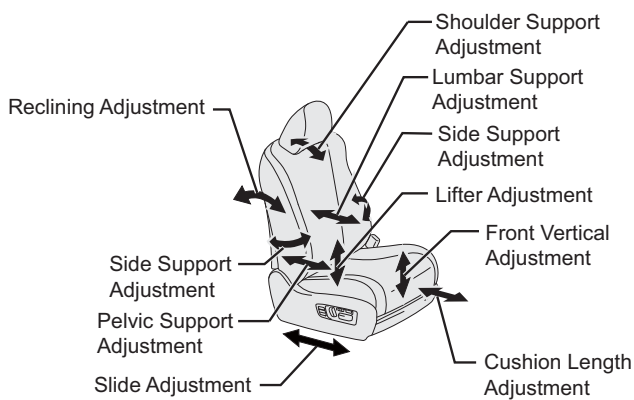

NOTICE

- The seat position adjustment functions of a power seat will be disabled when the 12 V battery is disconnected.

Front Seat

- When a vehicle is equipped with the driving position memory function, the driver seat automatically moves backward when the power switch is turned off (auto away function) and moves forward when the power switch is turned on (IG) (auto return function). Whether or not the vehicle is equipped with the driving position memory function can be confirmed by the existence of memory switches in the upper door trim.

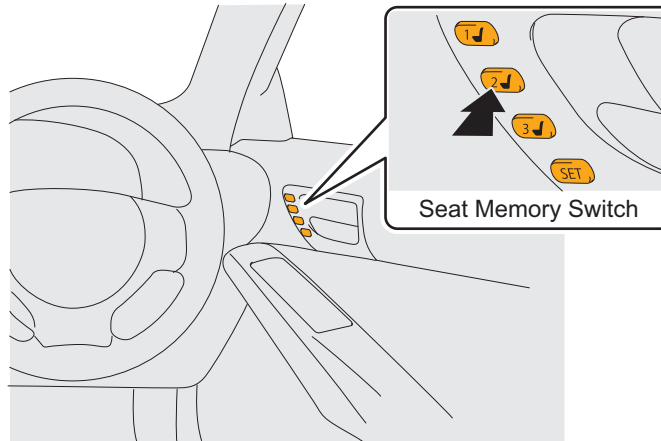

Rear Seat

- Two types of rear seats, a manual seat and a power seat, are available. When adjusting the seat position, a lever or a knob is operated for the manual seat and a switch is operated for the power seat.

Manual Seat

- The seat can be moved forward/backward by lifting the slide lever (slide adjustment).
- The seatback can be tilted forward/backward by lifting the reclining lever (reclining adjustment).
- The seat can be tilted forward by pulling the reclining strap.
- The seat can be moved leftward/rightward by lifting the lateral slide handle (lateral slide adjustment).
- The ottoman can be raised/lowered by lifting the ottoman lock handle (ottoman angle adjustment).
- The seat can be turned around by operating the swivel lever.

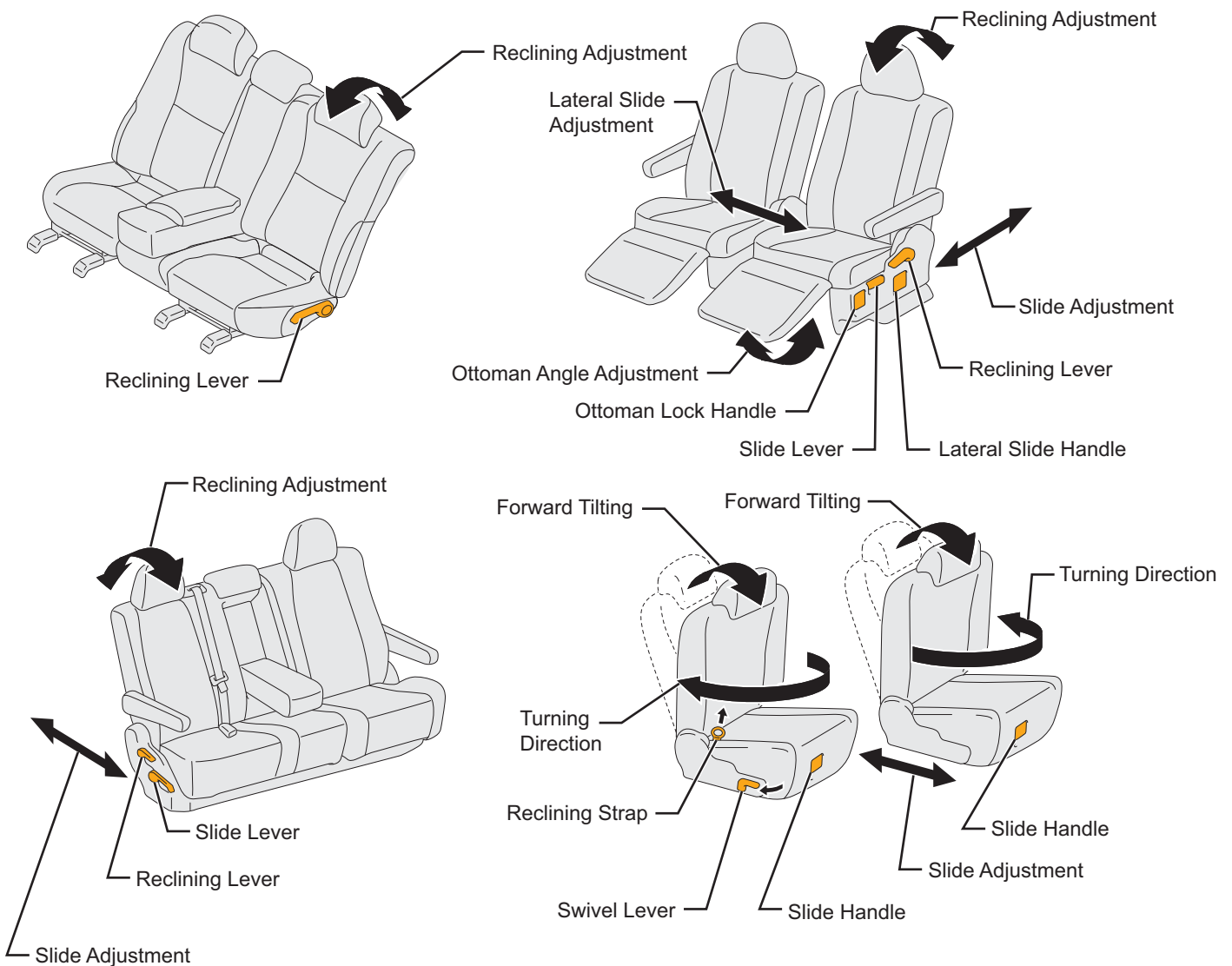

Power Seat

- The seat can be moved forward/backward by operating the slide adjustment switch (slide adjustment).
- The seatback can be tilted forward/backward by operating the reclining adjustment switch (reclining adjustment).
- The ottoman can be raised/lowered by operating the ottoman angle switch (ottoman angle adjustment).
- The angle of the upper seatback can be adjusted vertically by operating the seatback bend angle switch (seatback bend angle adjustment).
- The headrest can be raised/lowered by operating the headrest vertical adjustment switch (headrest vertical adjustment).

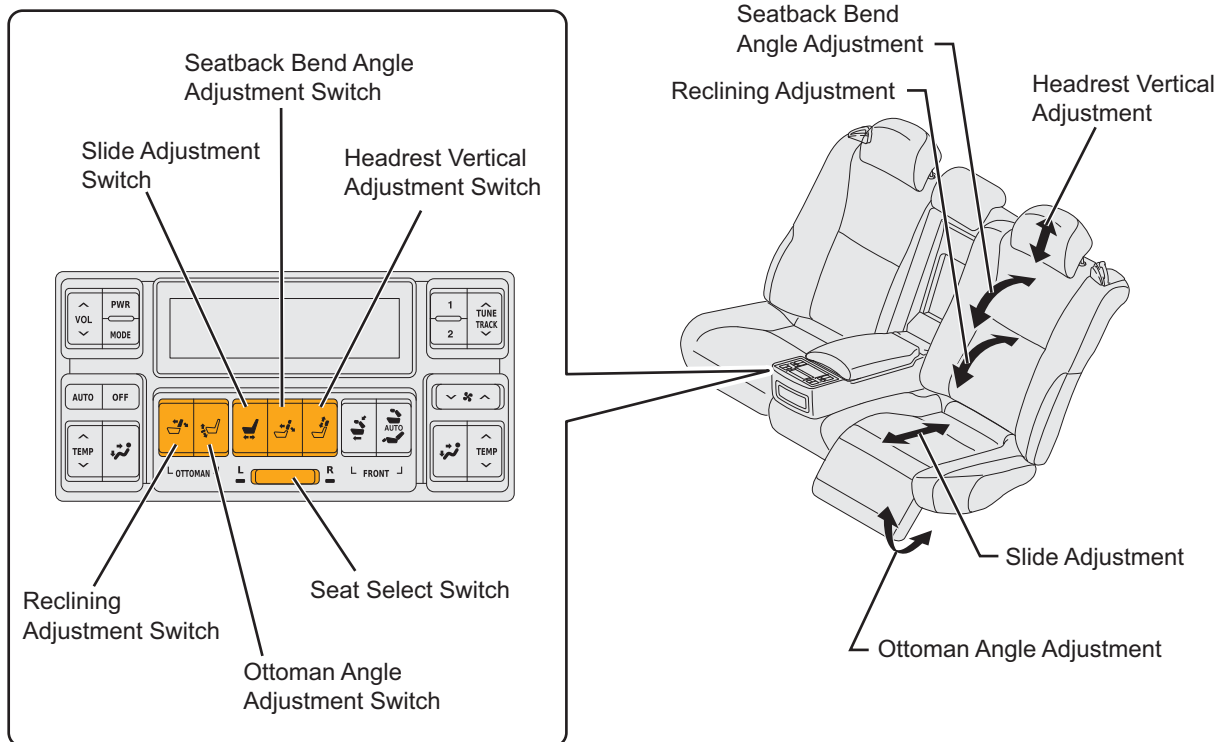

Headrest

- The position of the headrests can be adjusted vertically and horizontally.
- Two types of headrests, a manual headrest and a power headrest, are available. Vertical adjustment of the headrest is performed by hand on manual headrests or by operating a switch on power headrests. Horizontal adjustment can be performed by hand only.

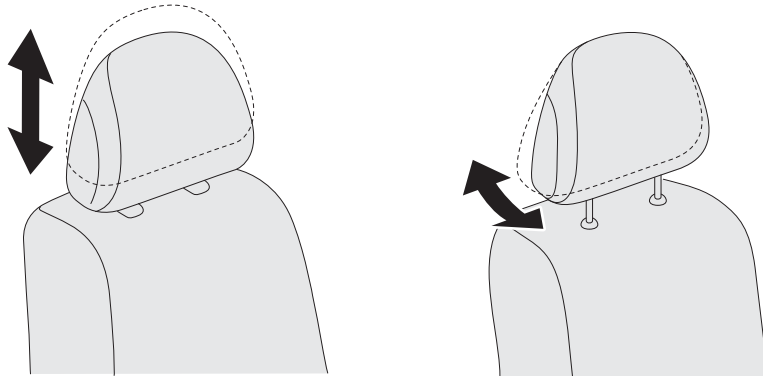

Manual Headrest

- When raising a manual headrest, pull up the headrest by hand. When lowering, push down the headrest while pushing the release button. To remove the headrest, pull out the headrest while pushing the release button.

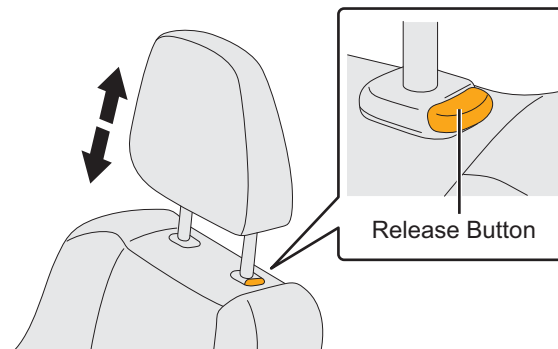

NOTICE

- If the headrest cannot be removed by pushing the release button, insert a screwdriver into the release hole provided on the opposite side of the headrest from the release button to release the lock and pull out the headrest.

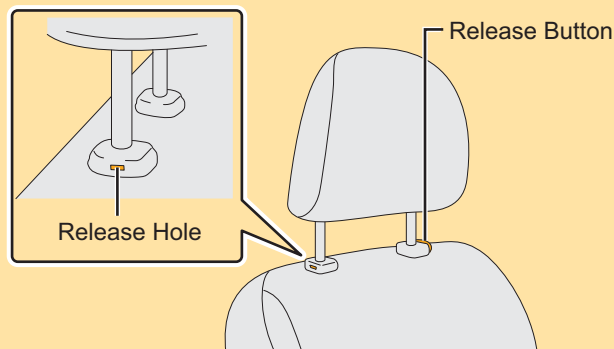

Headrest

Power Headrest

- When raising a power headrest, raise/lower the headrest by operating the power seat switch located on the side of the seat.

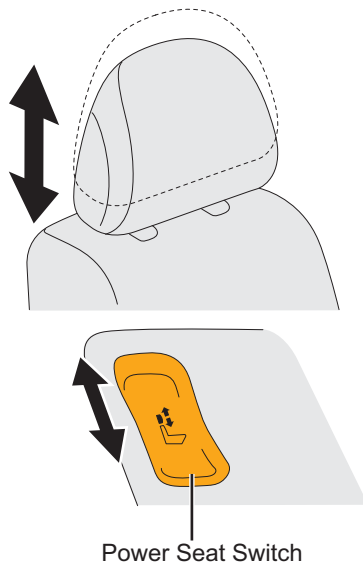

NOTICE

- To remove the headrest, disengage the pins located inside the seatback and pull out the headrest.

Back of the Seatback

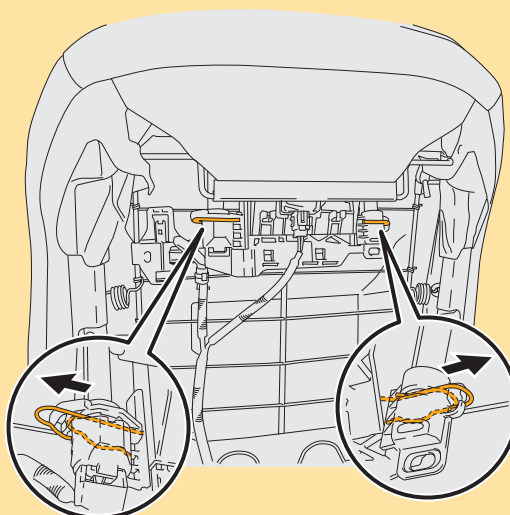



Active Headrest System

- The active headrest system is built into the front headrests.
- The active headrest system consists of an inflator, a rod and a link mechanism.
- When the airbag sensor detects a rear impact, an ignition signal is sent to the inflators to activate the active headrest system. When an inflator is ignited, pressure inside the inflator rises, pushing up a piston. As the piston rises, the rod in the headrest stay is pushed up, a lock is released via the link mechanism and the headrest is pushed forward by a spring, helping reduce the possibility of whiplash injuries.

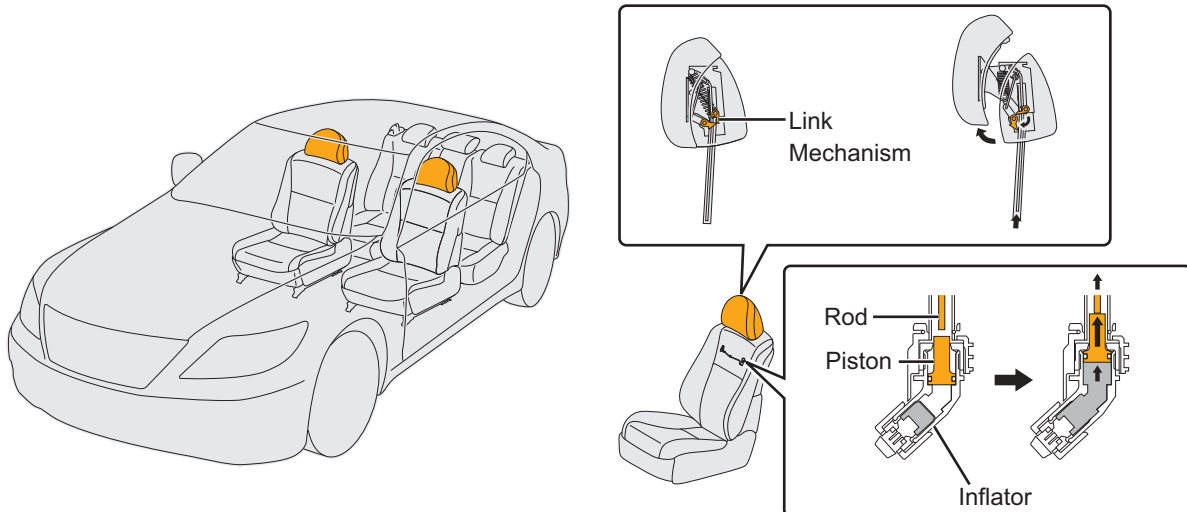

- The active headrest system may remain powered for up to 90 seconds after the vehicle is shut off and disabled (see page 72). Wait at least 90 seconds before starting any operation. Failure to shut off and disable the vehicle before emergency response procedures are performed may result in serious injury or death from unintentional actuation of the active headrest.
- If an inflator is cut, the active headrest inflator may unintentionally deploy. To prevent serious injury or death from unintentional active headrest actuation, avoid breaching the inflators.

Tilt & Telescopic Steering

- The steering column has a tilt mechanism, which enables vertical adjustment of the steering wheel position, and a telescopic mechanism, which enables horizontal adjustment of the steering wheel position.
- Two types of tilt & telescopic steering, manual tilt & telescopic steering and power tilt & telescopic steering, are available. When adjusting the position of the steering wheel, a lever is operated for the manual tilt and telescopic mechanisms and a switch is operated for the power tilt and telescopic mechanisms.
- Some vehicles have only tilt or telescopic mechanism, not both. Also, some vehicles have a fixed type steering column (not equipped with tilt & telescopic mechanism), and some vehicles power mechanism is only for tilt or telescopic function.

Manual Tilt & Telescopic

- The manual tilt & telescopic steering is provided with a lock lever under or side of steering column for releasing the lock when adjusting the steering wheel position.
- When the lock lever is operated, the lock is released, allowing adjustment of the steering wheel position. After adjustment, the steering wheel can be locked in the desired position by returning the lock lever.

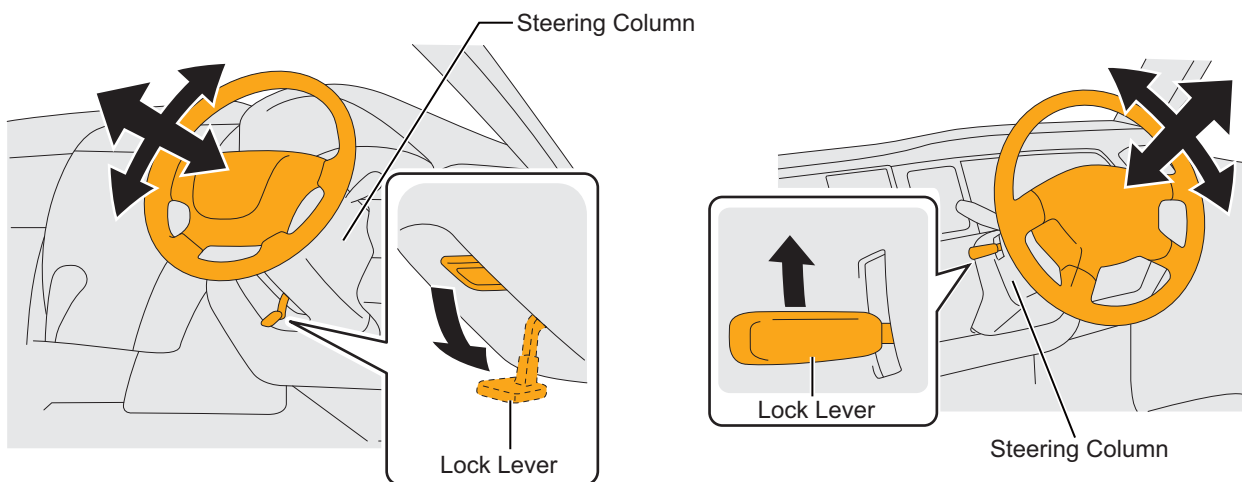

Power Tilt & Telescopic

- The power tilt & telescopic steering is provided with a switch on the steering column for adjusting the steering wheel position.
- The steering wheel can be moved to a desired position by operating the switch.

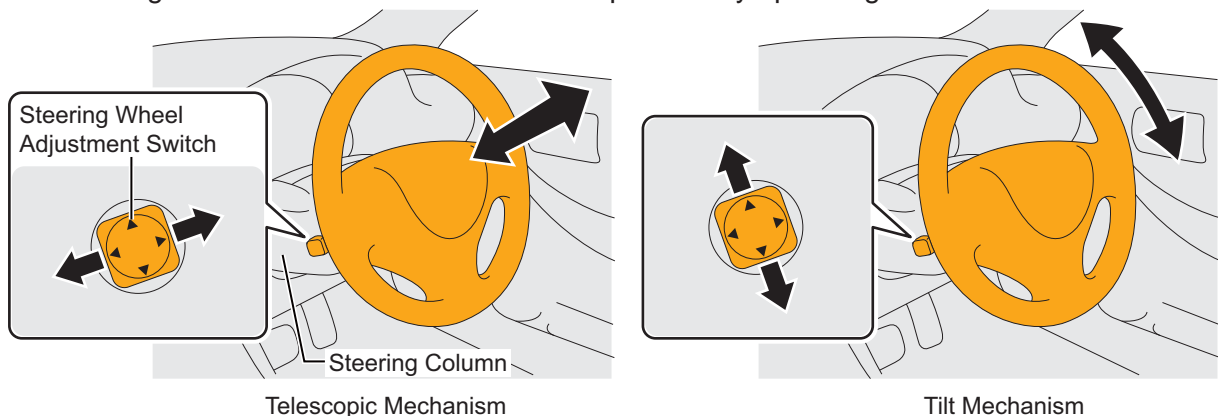

Doors

- The door is opened by operating the handle on the door.
- Some models are equipped with an access door (double door), which is opened using the inner door handle, or a back door, which is opened by using the back door handle after lowering the back window glass.

Flush Handle Type

- When voltage is not supplied, such as when the terminal of the 12 V battery is disconnected, the flush handle will not be deployed electrically. In this case, the door handle must be opened manually.
 1. The retracted door handle can be pulled out by pushing on the front end.
 2. The door can be opened by pulling more on the pulled out door handle.

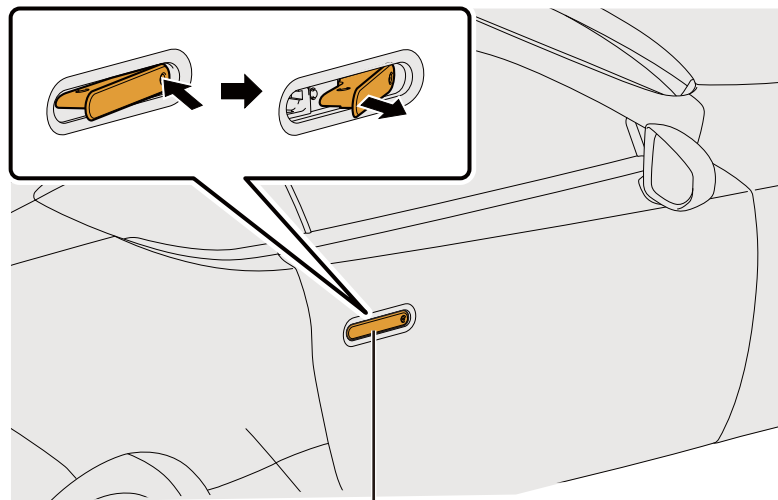

Door Handle



NOTICE

- If the door lock is engaged, insert the mechanical key into the flush handle to release the lock.

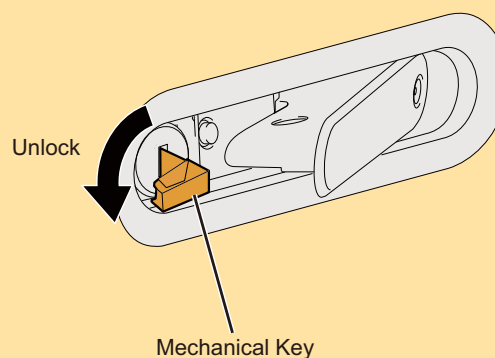

Doors

Access Door (Double door)

1. Open the front door as much as possible.
2. Pull the door handle on the access door forward.
3. Open the access door.

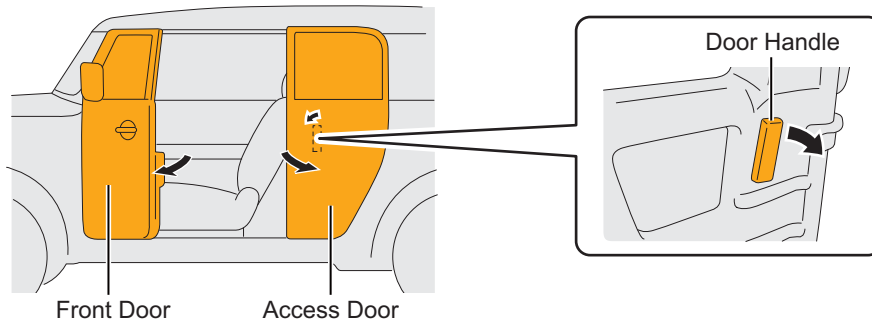

- Before opening either access doors, make sure the front seatbelt is unfastened. If the access door is opened with the front seatbelt fastened, the seatbelt may be locked and squeeze the front occupant, resulting in a serious injury.

Back Door

1. Insert a key into the key cylinder in the back door then turn the key clockwise to lower the back window glass.
2. Pull up the lock knob on the back door to release the lock.
3. Pull up the back door handle to open the back door.

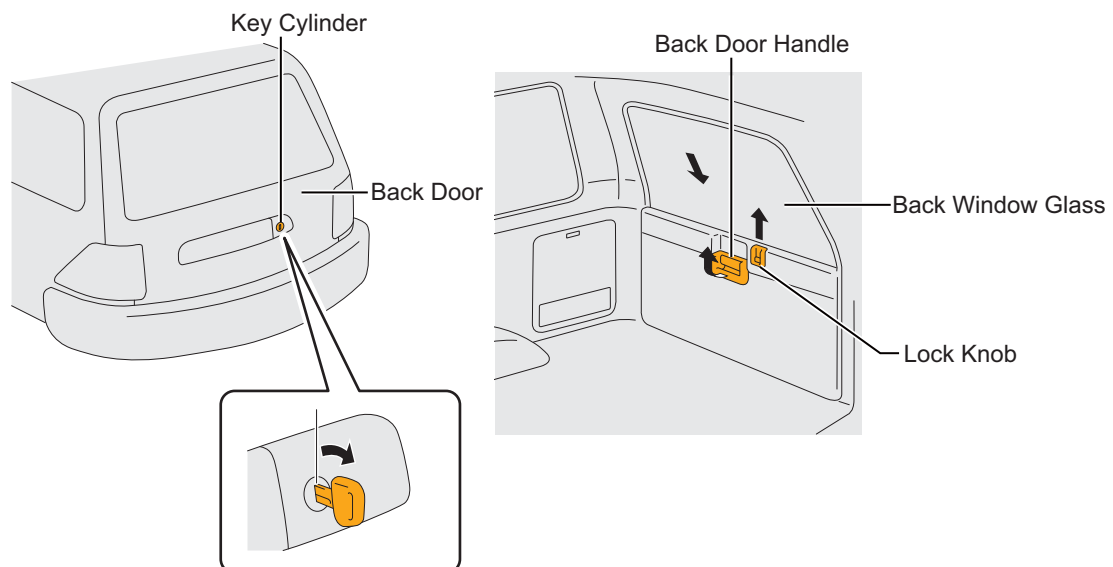

Emergency Response Key Points

- Procedures and points to be noted when handling TOYOTA/LEXUS vehicles during emergency response are provided in this section.
- Refer to the Quick Reference Sheet (QRS) for each model for model specific information such as vehicle identification points, component locations, etc.

Vehicle Identification

Appearance and Logos

- Identify the vehicle type based on exterior features and logos on the body.
- Logo marks represent the make, model, grade, and the vehicle type (hybrid/electric/fuel cell) if it uses a high voltage electrical system.
- Logo marks are attached to the trunk lid, back door/hatch, rocker panels, front grille and fender.

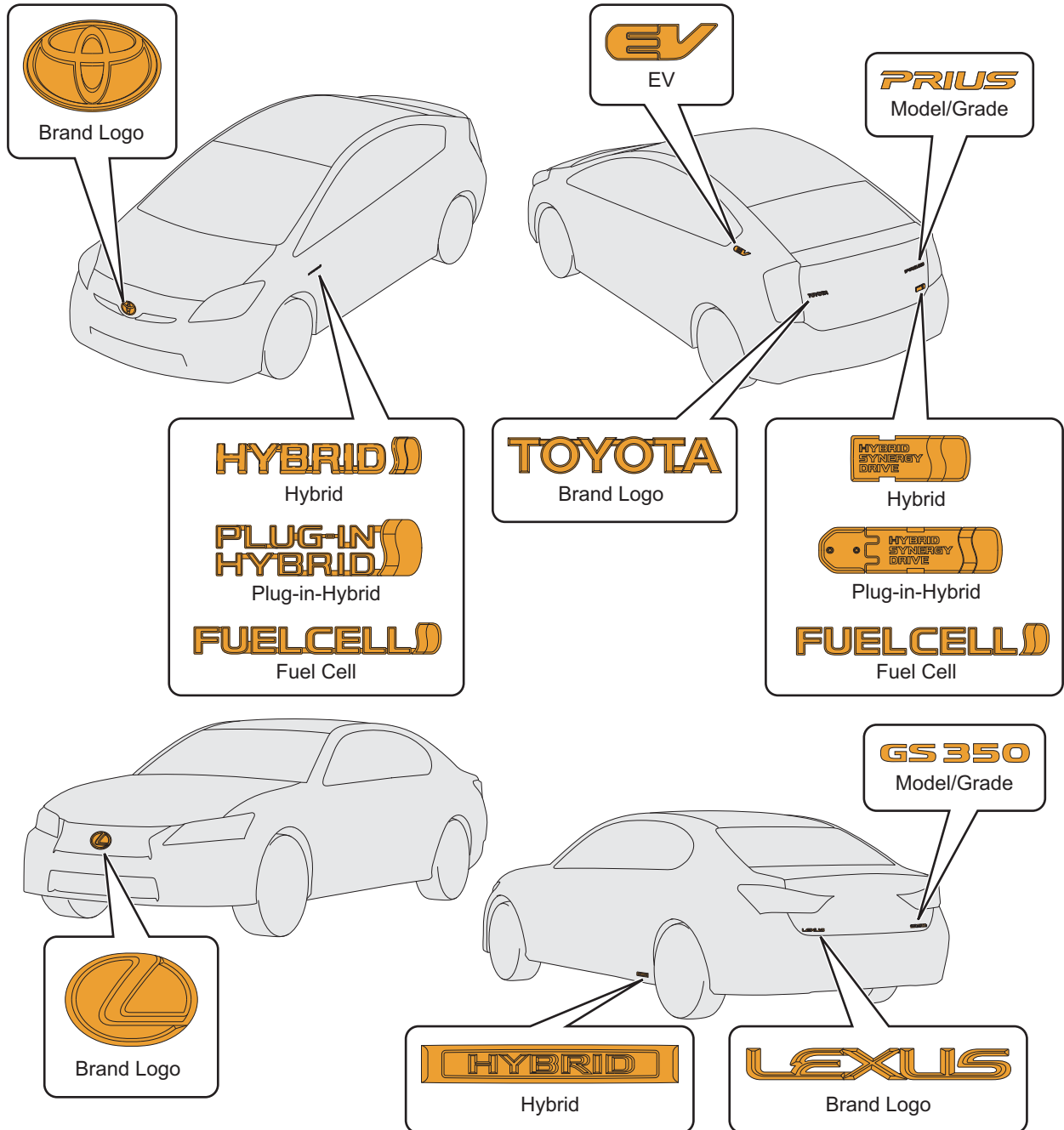

Vehicle Identification

Frame Number

- A frame number is stamped on the name plate attached to the engine compartment and front passenger door pillar.
- Characters before a hyphen (e.g.: ○○○○ for the frame number ○○○○-△△△△) represent the vehicle model.
- When a cover is installed under the driver seat, a frame number is stamped on the frame underneath the cover.

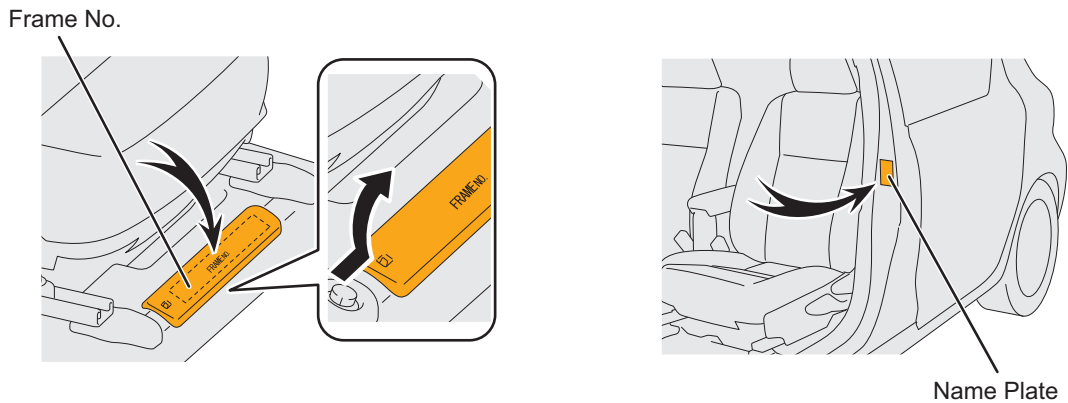

Vehicle Identification Number (VIN)

- The VIN is stamped on the name plate attached to the windshield cowl and driver door pillar.
- The vehicle model can be identified by the VIN.

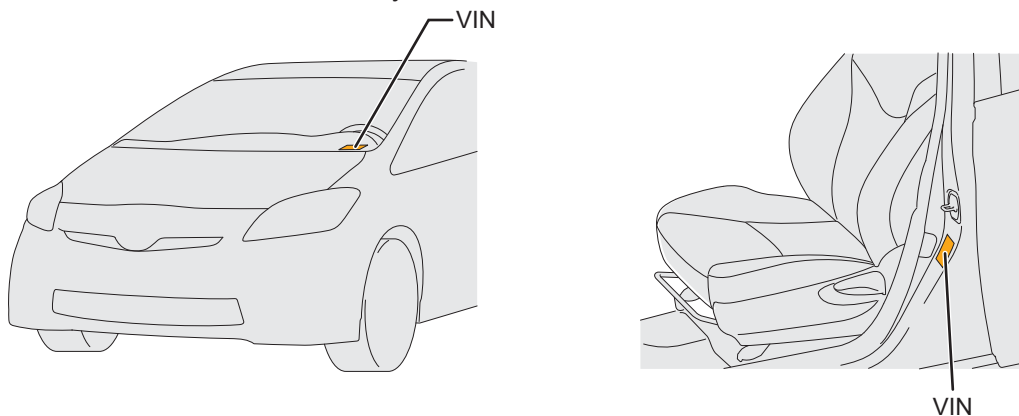

Immobilize Vehicle

- On arrival, completely immobilize the vehicle by following procedures 1, 2 and 3 to ensure safe emergency response operations.

1. Chock wheels and set the parking brake.

- The following types of parking brakes are available. Operate the parking brake accordingly.

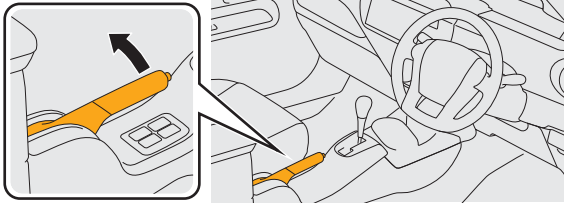

Lever Type

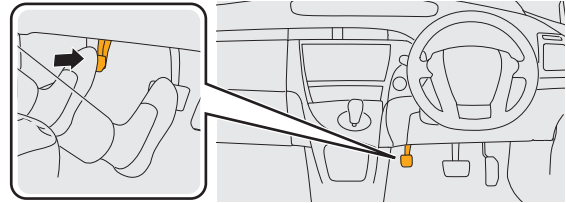

Foot Pedal Type

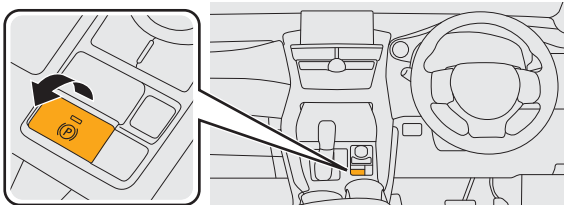

Switch Type
(Pull-type Switch)

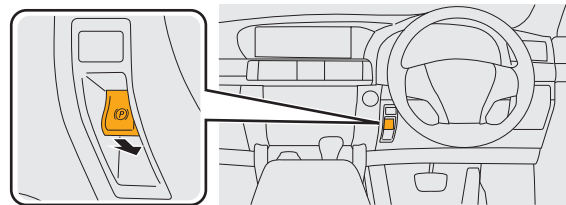

Switch Type
(Push-type Switch)

- For vehicles with a switch type, operate the switch twice in order to make sure that the vehicle is securely fixed in place.

2. For automatic vehicles, move the shift lever to the park (P) position. For manual vehicles, shut off the vehicle (see page 72), then move the shift lever to the 1st or reverse (R).

- Park (P) can be selected by the following methods. Operate the vehicle accordingly.

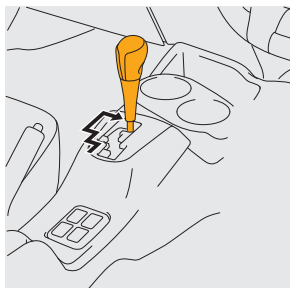

Shift Lever Type

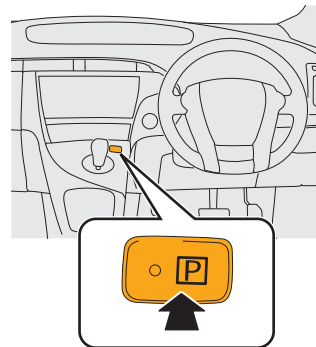

P Position Switch Type

Immobilize Vehicle

3. To facilitate emergency response operations, lower the windows, open the back door, unlock the doors and take other necessary actions before shutting off the vehicle.

■ The following systems are powered by the 12 V battery. Operate them as required before disconnecting the battery.

- Power door lock
- Power window
- Power tilt and telescopic steering
- Power seat

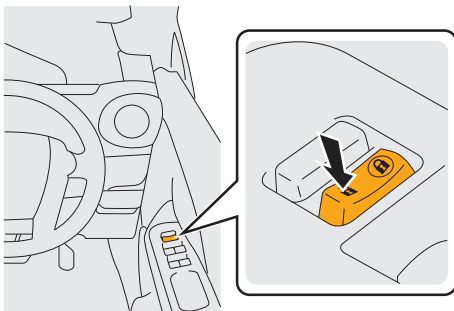

Door Unlock

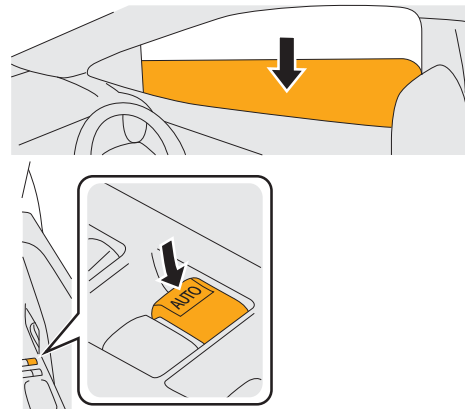

Power Window Adjustment

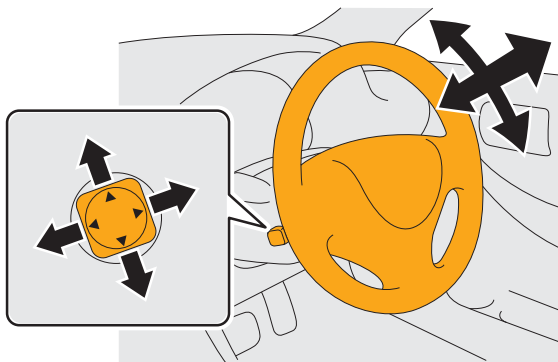

Steering Wheel Adjustment



Seat Adjustment



NOTICE

■ Once the 12 V battery is disconnected (see page 72), power controls will not operate.

Vehicle with High Voltage Battery

- Hybrid vehicles (HV), plug-in hybrid vehicles (PHV), electric vehicles (EV) and fuel cell vehicles (FCV) are equipped with a high voltage electrical system (over 144 V, up to 650 V).



- To prevent serious injury or death from severe burns or electric shock, avoid touching, cutting, or breaching any orange high voltage power cable or high voltage component. Wear appropriate protective equipment such as insulated gloves when there is a risk of touching high voltage power cables or high voltage components.

Vehicle with Hydrogen Gas

- Fuel cell vehicles (FCV) carry compressed hydrogen gas. Before performing the normal procedures to immobilize the vehicle, follow the steps below first.



- Hydrogen gas is colorless, odorless and flammable.
- Compared to gasoline or natural gas, hydrogen gas can ignite in a wide range of concentrations (4 to 74.5%). If the sound of hydrogen leaking (a loud hissing sound) can be heard when working on the vehicle, or if the hydrogen concentration around the vehicle exceeds 4% when measured with a hydrogen concentration detector, immediately step away from the vehicle as there is a chance that the hydrogen gas may ignite.



- Depending on the model, multiple hydrogen tanks may be installed. For the detailed installation locations of hydrogen tanks for each model, refer to the Quick Reference Sheet (QRS) for each model.

1. Confirm that there is no sound of hydrogen leakage (a loud hissing sound).
 - When approaching the vehicle, approach from the front.
 - If the sound of leakage can be heard, immediately step away from the vehicle, as the hydrogen may ignite.
 - Confirm that the sound of leakage is no longer present before proceeding to the next procedure.
2. Using a hydrogen concentration detector, measure the hydrogen concentration around the vehicle, and confirm that it does not exceed 4%.
 - If the concentration exceeds 4%, immediately step away from the vehicle, as the hydrogen may ignite.
 - If a ventilator is available, fanning the area can reduce the hydrogen concentration. Blow the fan from the front toward the rear of the vehicle. When approaching the vehicle, approach from the direction where the wind is coming from.

- Measure the hydrogen concentration at regular intervals and confirm that the hydrogen concentration does not exceed 4% before proceeding to the next step.

3. Immobilize the vehicle according to the normal procedures.

4. Flow chart of actions required before performing emergency response procedures

- Make sure to wear insulated gloves and anti-static shoes and check that the hydrogen concentration is below the flammability limit (4%).

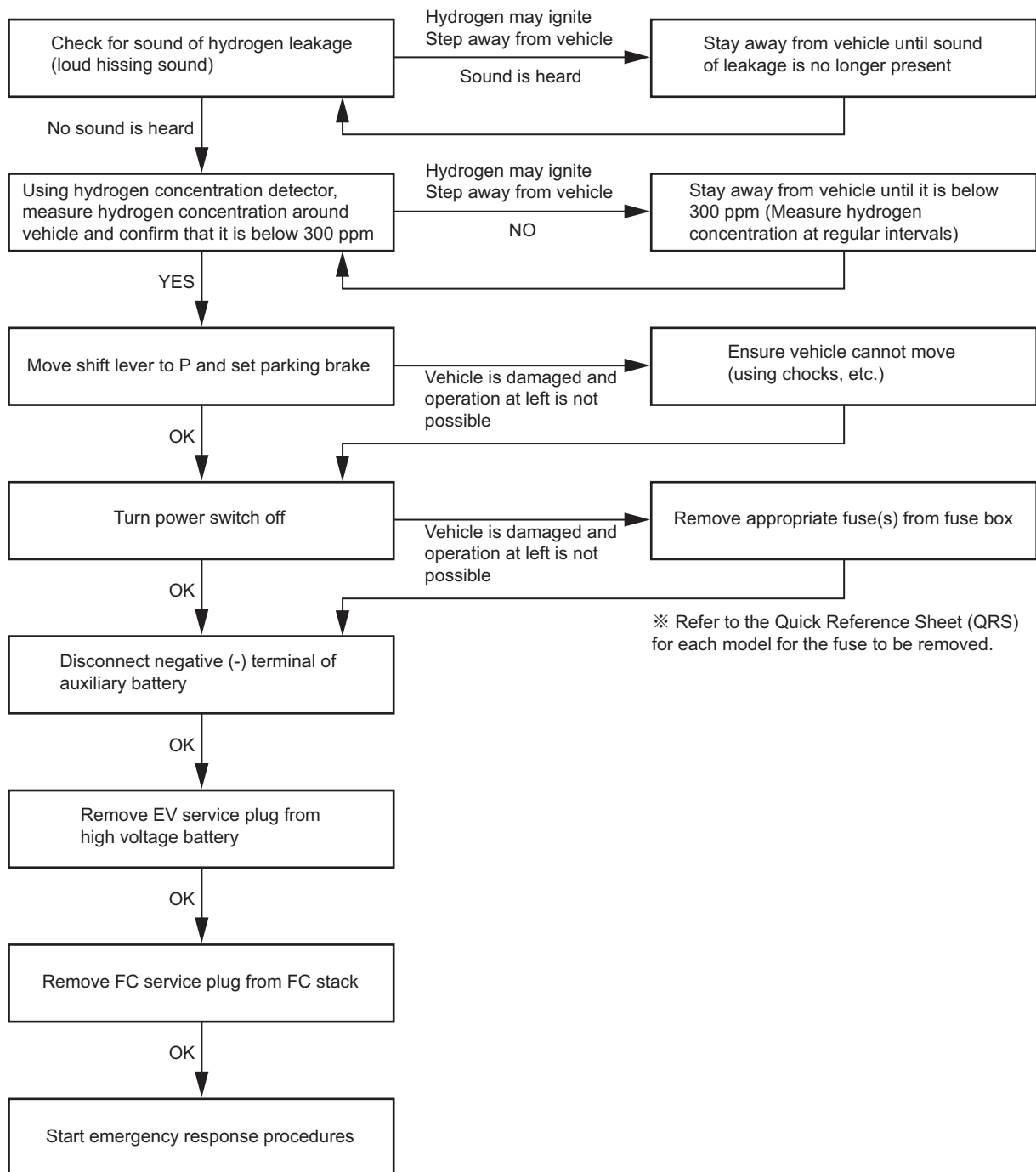

Disable Vehicle

- To ensure safe emergency response operations, the vehicle must be completely turned off by shutting off the power from the fuel pump, SRS airbag, high voltage battery, plug-in charging system, etc.
- Confirm the vehicle status. If **any of the following conditions exist**, the vehicle may not shut off.

- Engine is running.
- Ignition switch is in ACC, ON or START position.
- Meters are illuminated.
- Air conditioning is operating.
- Audio system is operating.
- Wipers are operating.
- Navigation or other displays are turned on.
- Charge cable is connected.



- NEVER assume the vehicle is shut off simply because it is silent. If the vehicle is equipped with an idling stop system, or the vehicle is a hybrid vehicle (HV) or plug-in hybrid vehicle (PHV), the engine is silent while the vehicle is on. Make sure none of the above conditions exist.
- Failure to shut off and disable the vehicle before emergency response procedures are performed may result in serious injury or death from unintentional deployment of the SRS airbags or unintentional actuation of the seatbelt pretensioners, pop up hood, or active headrests.

- Completely shut off the vehicle by following procedures 1 or 2.

Procedure 1

1. Turn the ignition switch to the LOCK (OFF) position or push the engine/power switch once to shut off the vehicle.

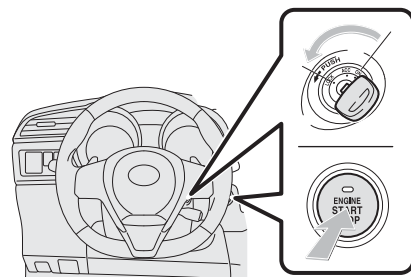

- If the vehicle is equipped with an engine/power switch the vehicle is shut off when **ALL of the following conditions are met**. With all of the following conditions met, do not push the engine/power switch as the vehicle will start.
 - Engine is not running.
 - Meters are not illuminated.
 - Air conditioning is not operating.
 - Audio system is not operating.
 - Wipers are not operating.
 - Navigation and other displays are turned off.
 - Charge cable is disconnected.

Disable Vehicle



NOTICE

- The engine/power switch operates as follows.
With the brake pedal (for automatic vehicles) or the clutch pedal (for manual vehicles) depressed:
Vehicle Start → Stop → Start ... is repeated every time the switch is pushed.
- With the brake pedal (for automatic vehicles) or the clutch pedal (for manual vehicles) released:
Accessory → Ignition-On → Off → Accessory... is repeated.
- When in "Accessory" mode, the radio and other accessory components are operational.
- When in "Ignition-On" mode, the power windows, wipers, heater/air conditioner fan and other components including SRS system are operational.
- The vehicle will not start if the brake pedal (for automatic vehicles) or the clutch pedal (for manual vehicles) is not depressed, even if the switch is pushed.

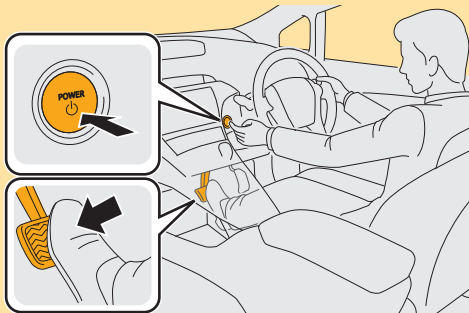

Brake Pedal Depressed

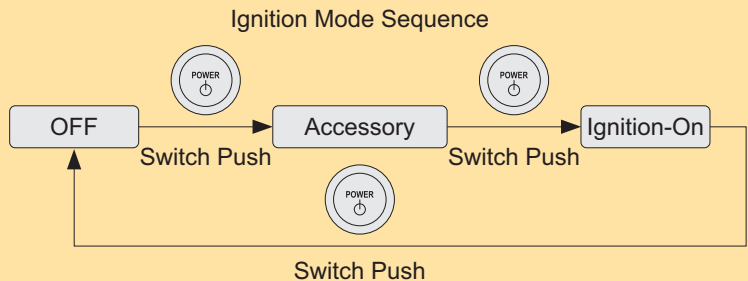

Brake Pedal Released

2. When the vehicle is equipped with an engine/power switch, keep the electrical key transmitter 5 meters (16.4 feet) or more away from the vehicle.



NOTICE

- If the electrical key transmitter is in the cabin or near the vehicle, the vehicle may start depending on what operations are performed. For example, if the engine/power switch is pushed.
- To prevent unexpected starting of the vehicle, place the electrical key transmitter outside of the detection area.

Disable Vehicle

3. Disconnect the negative (-) terminal of the 12 V battery.

- The 12 V battery is installed in the engine compartment, in the luggage compartment or under the rear seat.
- Refer to the Quick Reference Sheet (QRS) for each model for the location of the 12 V battery.

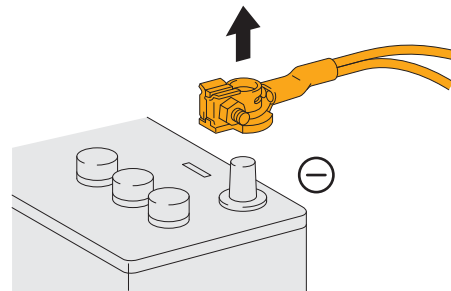

NOTICE

- Shut off the power to the electrical system to prevent electrical fires and to keep the vehicle from starting.
- After the negative (-) terminal of the 12 V battery has been disconnected and the power has been shut off, approximately 12 V is maintained between the positive (+) terminal and negative (-) terminal of the sub-battery for up to approximately 10 minutes.

Procedure 2 (Alternate if the ignition switch or power switch is inoperative)

1. Open the hood. Remove the engine room covers, if any are present.

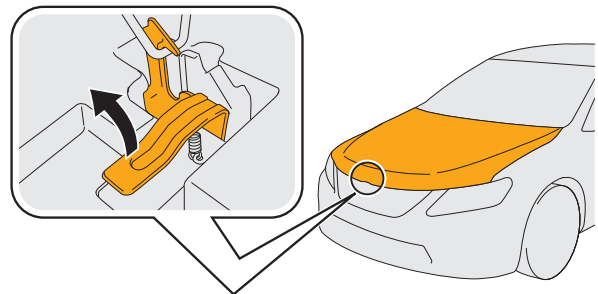

2. Remove the engine compartment fuse box cover.

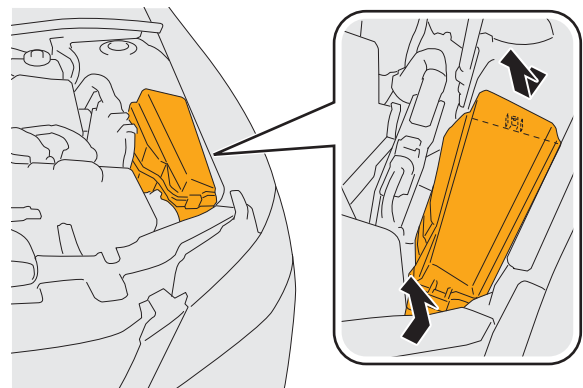

Disable Vehicle

3. Remove the appropriate fuse.

- Refer to the Quick Reference Sheet (QRS) for each model for the fuse to be removed.

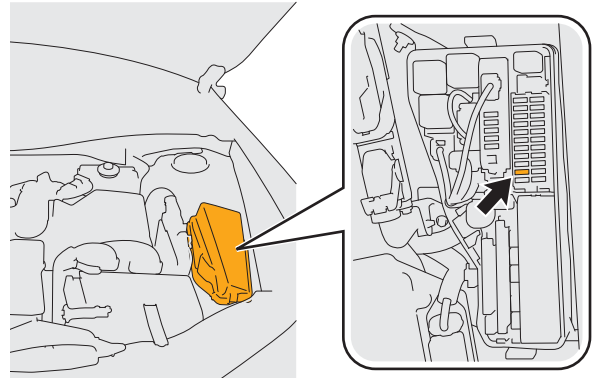

- If the correct fuse cannot be identified, pull **ALL** fuses in the fuse box **until all of the following conditions are met.**

- Engine is not running.
- Meters are turned off.
- Air conditioning is turned off.
- Audio system is turned off.
- Wipers are turned off.
- Navigation and other displays are turned off.

4. Disconnect the negative (-) terminal of the 12 V battery.

- The 12 V battery is installed in the engine compartment, in the luggage compartment or under the rear seat.
- Refer to the Quick Reference Sheet (QRS) for each model for the location of the 12 V battery.

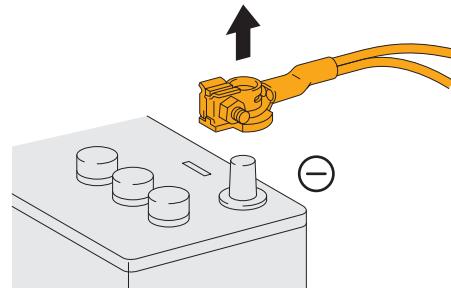

- Shut off the electrical system to prevent electrical fires and to keep the vehicle from starting.
- After the negative (-) terminal of the 12 V battery has been disconnected and the power has been shut off, approximately 12 V is maintained between the positive (+) terminal and negative (-) terminal of the sub-battery for up to approximately 10 minutes.

Vehicle with High Voltage Battery

- Hybrid vehicles (HV), plug-in hybrid vehicles (PHV), electric vehicles (EV) and fuel cell vehicles (FCV) are equipped with a high voltage electrical system (over 144 V, up to 650 V).



- The high voltage system may remain charged for up to 10 minutes after the vehicle is shut off and disabled (see page 72). Failure to shut off and disable the vehicle before emergency response procedures are performed may result in serious injury or death from severe burns and electric shock from the high voltage electrical system.
- To prevent serious injury or death from severe burns or electric shock, avoid touching, cutting, or breaching any orange high voltage power cable or high voltage component. Wear appropriate protective equipment such as insulated gloves when there is a risk of touching high voltage power cables or high voltage components.
- NEVER assume the hybrid vehicle (HV), plug-in hybrid vehicle (PHV) or electric vehicle (EV) is shut off simply because it is silent. Always observe the instrument cluster for the **READY** indicator status to verify whether the high voltage system is on or shut off. The high voltage system is shut off when the **READY** indicator is off.
- When the vehicle is equipped with a remote air conditioning system and the meters are illuminated, high voltage may be applied to the air conditioning system even though the **READY** indicator is off. Shut off and disable vehicle and ensure the meters are turned off.

Vehicle with Plug-in Charge System

- Plug-in hybrid vehicles (PHV) and electric vehicles (EV) are equipped with a system to charge the high voltage battery using power from an external power source.
- If a charge cable is connected to the charging inlet of the vehicle, disconnect the charge cable as follows to stop charging.

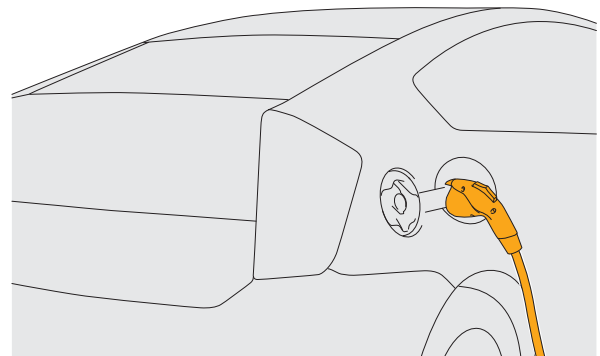

Disable Vehicle

1. Push the latch release button on the top of the charging connector and pull it away from the charging inlet of the vehicle.

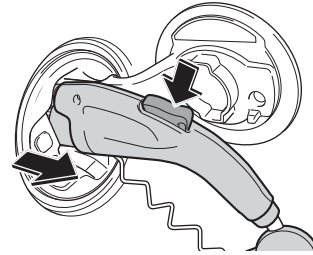

NOTICE

- Some plug-in hybrid vehicles and electric vehicles have a connector locking system. The charging connector is unlocked by pressing the charging connector lock switch after unlocking the doors.
- If the lock of the charge cable assembly connector cannot be released, turn OFF or unplug the external charger, or turn its main breaker OFF.
- The lock of the charge cable assembly connector cannot be released during fast charging. If charging does not stop even when the charger is turned OFF, turn its main breaker OFF.

2. Close the charging inlet cap and charging port lid.

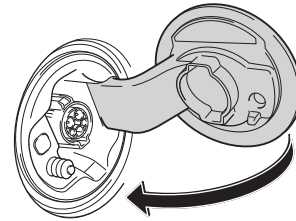

3. Turn off the external charger by unplugging it or turning its main circuit breaker off.

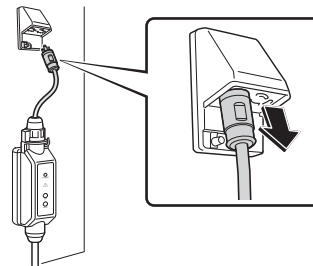

WARNING

- To prevent serious injury or death from severe burns or electric shock, shut off the utility circuit supplying power to the charge cable before disconnecting it if the vehicle, charge cable or external charger is submerged in water.

Disable Vehicle

Vehicle with Hydrogen Gas

- Fuel cell vehicles (FCV) carry compressed hydrogen gas. In order to abort refueling, follow the steps below.

1. Operate the hydrogen station to abort refueling.



NOTE

- Hydrogen inside the hose will depressurized and the filling nozzle can now be removed.

2. Remove the filling nozzle of the hydrogen station from the refueling port (receptacle).

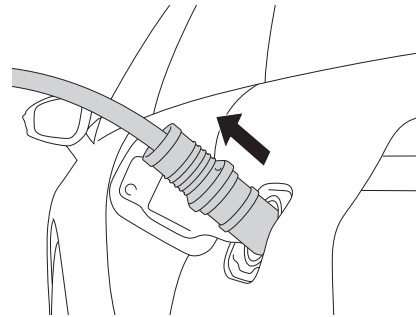

3. Put the cap on the refueling port (receptacle).

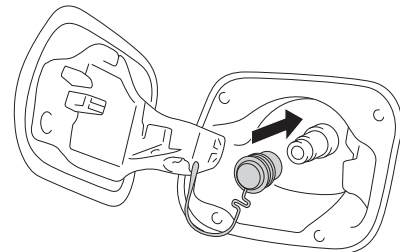

4. Close the fuel door.

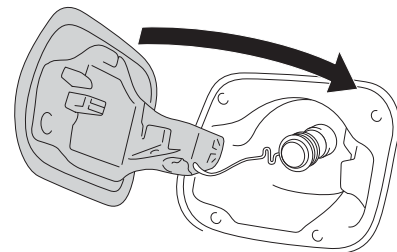

WARNING

- For fuel cell vehicles (FCV), even if the READY indicator turns off, the high voltage system may still be active if the H₂O indicator in the combination meter is illuminated. Shut off and disable the vehicle and ensure the meters are turned off.

Stabilize Vehicle

- Crib at four points directly under the front and rear pillars using wooden blocks or equivalent objects.

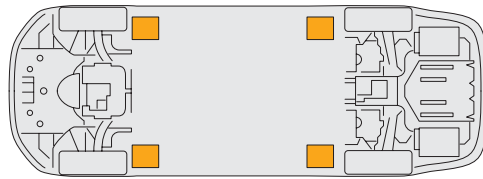
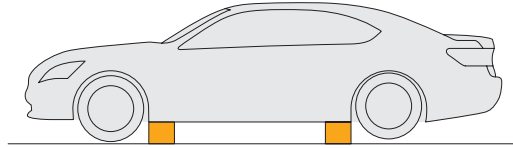

WARNING

- Do not place cribbing such as wooden blocks or rescue air lifting bags under the exhaust system, fuel system or high voltage power cables. Failure to do so may cause heat generation, bursting of the air lifting bags, damage to the high voltage power cables or damage to the hydrogen piping, resulting in a vehicle fire, crushing accident, electrical shock or gas leak, possibly leading to serious injury or death.

Access Patients

- Make sure that the vehicle is immobilized and disabled (see page 72), then open or remove windows and doors to access patients.
- Secure the necessary space for performing operations by adjusting the position of the steering wheel and seats and removing the head rests.
- Refer to “Components Requiring Special Attention” for details of adjustment and removal of components.



WARNING

- The SRS airbags, seatbelt pretensioners, pop up hood and active headrests may remain powered for up to 90 seconds after the vehicle is shut off and disabled (see page 72). Wait at least 90 seconds before starting any operation. Failure to shut off and disable the vehicle before emergency response procedures are performed may result in serious injury or death from unintentional deployment of the SRS airbags or unintentional actuation of the seatbelt pretensioners, pop up hood or active headrests.
- Depending on the circumstances surrounding a collision, such as vehicle speed, point of impact, occupant detection etc., the SRS airbags, seatbelt pretensioners, pop up hood or active headrests will not always be activated and may remain active. If an unactivated inflator of these systems is cut, the powder inside the inflator may ignite resulting in airbag deployment. To prevent serious injury or death from unintentional SRS airbag deployment or unintentional actuation of the seatbelt pretensioners, pop up hood or active headrests, avoid breaching the inflators.
- Immediately after an SRS airbag is deployed or a seatbelt pretensioner, the pop up hood or an active headrest is actuated, the components are extremely hot and may cause burns if touched.
- If an SRS airbag deploys with all doors and windows closed, inflation gas may cause breathing difficulty.
- If residue that is produced during the operation of SRS airbags, seatbelt pretensioners, pop up hood or active headrests comes in contact with skin, rinse it off immediately to prevent skin irritation.

Vehicle with High Voltage Battery

- Hybrid vehicles (HV), plug-in hybrid vehicles (PHV), electric vehicles (EV) and fuel cell vehicles (FCV) are equipped with a high voltage electrical system (over 144 V, up to 650 V).



WARNING

- The high voltage system may remain charged for up to 10 minutes after the vehicle is shut off and disabled (see page 72). Failure to shut off and disable the vehicle before emergency response procedures are performed may result in serious injury or death from severe burns and electric shock from the high voltage electrical system.
- To prevent serious injury or death from severe burns or electric shock, avoid touching, cutting, or breaching any orange high voltage power cable or high voltage component. Wear appropriate protective equipment such as insulated gloves when there is a risk of touching high voltage power cables or high voltage components.

Vehicle with Hydrogen Gas

- Fuel cell vehicles (FCV) carry compressed hydrogen gas.



- Hydrogen gas is colorless, odorless and flammable.
- Compared to gasoline or natural gas, hydrogen gas can ignite in a wide range of concentrations (4 to 74.5%). If the sound of hydrogen leaking (a loud hissing sound) can be heard when working on the vehicle, or if the hydrogen concentration around the vehicle exceeds 4% when measured with a hydrogen concentration detector, immediately step away from the vehicle as there is a chance that the hydrogen gas may ignite.
- Even after the vehicle is stopped (see page 72), hydrogen remains inside the FC stack, hydrogen tanks and other hydrogen-related parts, as well as inside the hydrogen pipe. In order to avoid fires and explosions, never cut or damage these hydrogen-related parts or the hydrogen pipe.
- If there is any hydrogen leakage, do not use any electrical or rescue equipment that may produce static electricity, as this may ignite the hydrogen.

Cut Vehicle

- Pay special attention to the location of structural reinforcements, fuel system, SRS and high voltage electrical system components when cutting a vehicle.
- Refer to the Quick Reference Sheet (QRS) for each model for model specific information such as component locations, etc.

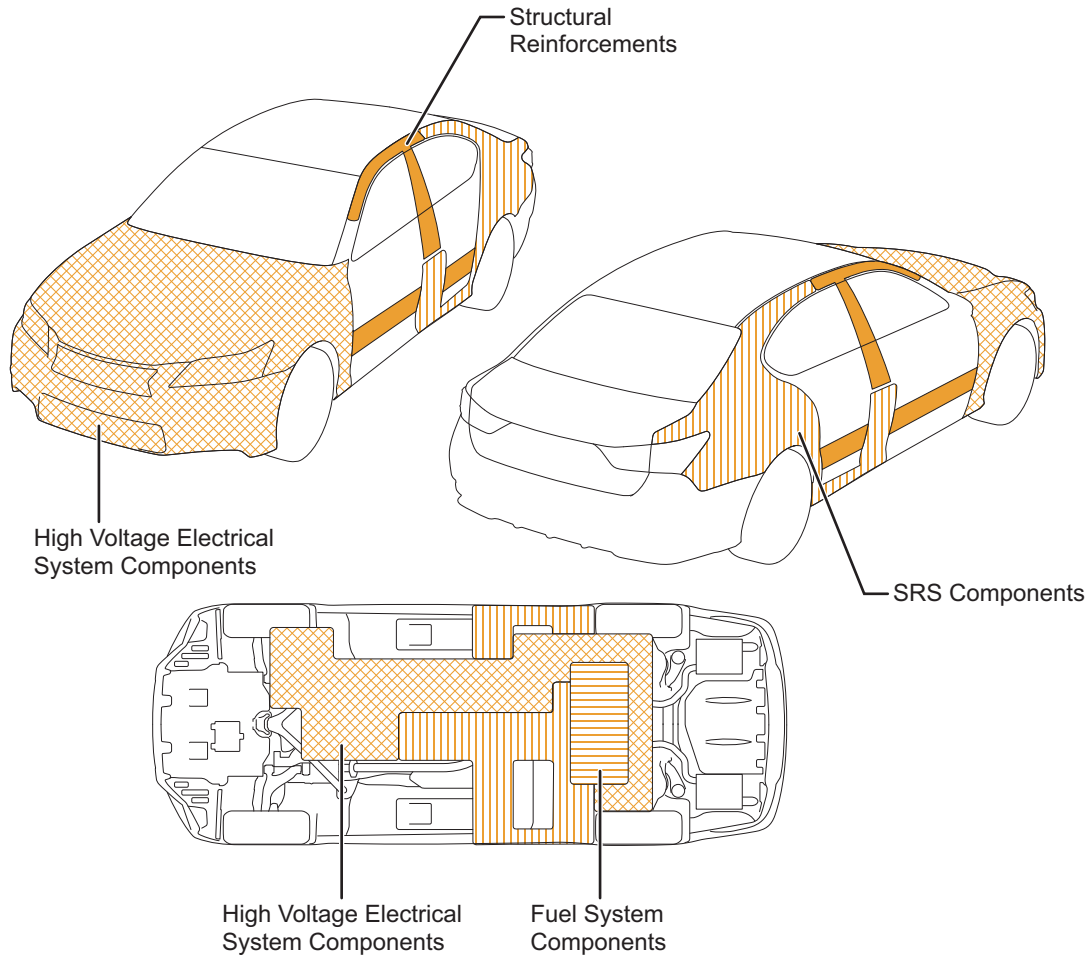

WARNING

- To prevent serious injury from a fire caused by sparks, use a hydraulic cutter or other tools that do not generate sparks when cutting the vehicle.



NOTE

- If the SRS airbag, seatbelt pretensioner, pop up hood or active headrest has already been activated, the inflator can be cut.

Fire

- During the initial attack on a fire, extinguish the fire with copious amounts of water. This will also cool down the vehicle.



- Plastic and other components will generate toxic gases when they melt. Wear appropriate protective equipment such as a protective mask when extinguishing a fire.

Fire Extinguisher

- Water has been proven to be a suitable extinguishing agent.
- Also use a fire extinguisher suitable for flammable liquid fires (burning of gasoline, grease, oil, etc.) and electrical fires (burning of electrical wiring, electric devices, etc.) as well as general fires (burning of solid objects, etc.).

Vehicle with High Voltage Battery

- Hybrid vehicles (HV), plug-in hybrid vehicles (PHV), electric vehicles (EV) and fuel cell vehicles (FCV) are equipped with a high voltage battery.
- Extinguish the fire with copious amounts of water to cool down the high voltage battery.
- Refer to the Quick Reference Sheet (QRS) for each model for the high voltage battery location.



- To avoid serious injury or death from severe burns or electric shock, never breach or remove the high voltage battery assembly cover under any circumstances, including fire.
- If only a small amount of water is used to extinguish a fire, a short circuit may occur in the high voltage battery, causing the fire to reignite.



- It is recommended to allow the high voltage battery to burn itself out if it is judged that it is difficult to apply copious amounts of water to the high voltage battery.

Vehicle with Lithium ion (Li-ion) Battery



- Burning Li-ion batteries may irritate the eyes, nose or throat. In case of contact with the vapor from the electrolyte, it may irritate the nose or throat. To avoid injury by coming in contact with the electrolyte or vapor, wear appropriate protective equipment such as rubber gloves, safety goggles, protective mask or SCBA when there is a risk of touching electrolyte.

Vehicle with Urea Solution

- Urea solution equipped vehicles have a urea tank that stores urea solution.



WARNING

- The urea solution is noncombustible. However, if the urea solution is heated due to a fire, etc., it breaks down and may emit a harmful gas. If you come in contact with smoke or vapor from a burning urea tank, it may irritate the eyes, nose or throat.
- To avoid injury by coming in contact with the smoke or vapor from a burning urea tank, wear appropriate protective equipment such as rubber gloves, safety goggles, a protective mask or SCBA when there is a risk of contacting the smoke or vapor.

Vehicle with Hydrogen Gas

- Fuel cell vehicles (FCV) carry compressed hydrogen gas.
- When dousing the vehicle, keep a distance of at least 10.0 meters (32.8 feet) in case of hydrogen igniting.
- Use larger amounts of water particularly on the vehicle's rear underfloor to cool the area where the hydrogen tanks are located.
- If the hydrogen is on fire, extinguishing the hydrogen flame completely could cause unburned hydrogen to accumulate and lead to a secondary explosion. Therefore, spray water to prevent the flame from spreading to surrounding areas, then wait for the hydrogen flame to naturally die down (burn itself out).
- In order to prevent an explosion when the temperature of the hydrogen reaches abnormal levels in case of a vehicle fire, the thermal pressure relief devices (TPRD) installed on the hydrogen tanks open when they exceed approximately 110°C (230°F), and the hydrogen inside the tank is released outside of the vehicle.
- A pure hydrogen fire is colorless and is not visible. However, in a vehicle fire, other flammable materials will also burn, allowing the fire to be visible.

Fire

- The temperature of a hydrogen fire itself is very high, but the amount of heat that radiates from the flame is small. It is unique in that it is difficult to feel the heat even in close proximity.

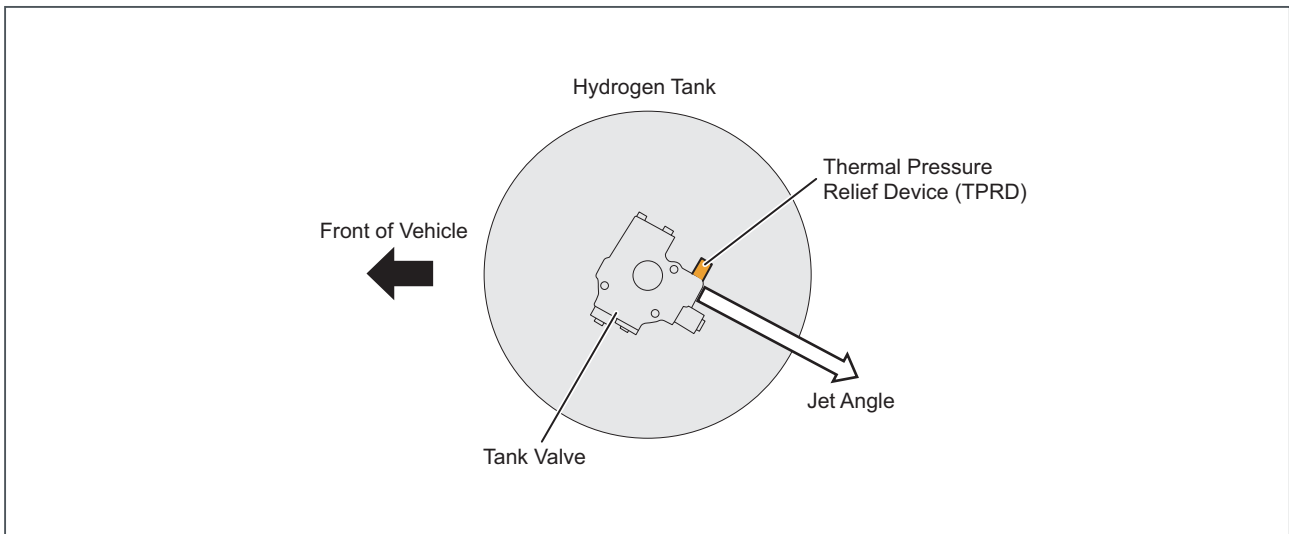

WARNING

- Hydrogen gas is colorless, odorless and flammable.
- Compared to gasoline or natural gas, hydrogen gas can ignite in a wide range of concentrations (4 to 74.5%). If the sound of hydrogen leaking (a loud hissing sound) can be heard when working on the vehicle, or if the hydrogen concentration around the vehicle exceeds 4% when measured with a hydrogen concentration detector, immediately step away from the vehicle as there is a chance that the hydrogen gas may ignite.



NOTICE

- Depending on the model, multiple hydrogen tanks may be installed. For the detailed installation locations of hydrogen tanks for each model, refer to the Quick Reference Sheet (QRS) for each model.

Submersion

- Pull the vehicle out of water as much as possible. Immobilize the vehicle (see page 68) and disable the vehicle (see page 72) before starting any operation.



- A short circuit due to electrical corrosion (wiring and circuit boards become corroded due to an electrochemical reaction with water) may cause a vehicle fire after some time has elapsed.
- To prevent a vehicle fire, avoid turning the ignition switch or power switch of a submerged vehicle to ACC or ON.

Vehicle with High Voltage Battery

- A partially or fully submerged hybrid vehicle (HV), plug-in hybrid vehicles (PHV), electric vehicle (EV) or fuel cell vehicle (FCV) does not have high voltage potential on the metal vehicle body, and is safe to touch.
- It is safe to enter the water as the vehicle and water have the same electrical potential.



- Touching exposed orange high voltage power cables or high voltage components such as the high voltage battery may cause electrical shock due to a change in electrical potential.
- To prevent serious injury or death from severe burns or electric shock, avoid touching, cutting, or breaching any orange high voltage power cable or high voltage component. Wear appropriate protective equipment such as insulated gloves when there is a risk of touching high voltage power cables or a high voltage components.

Spills

- Vehicles contain various fluids such as gasoline, coolant, engine oil, transmission oil, brake fluid, power steering fluid, window washer fluid and 12 V battery electrolyte.

Coolant

- Long Life Coolant (LLC) that is used to cool the engine and inverter contains ethylene glycol for freezing temperature control and anticorrosion additives for preventing metal components from corroding.

Lubrication Oil

- Engine oil, transmission oil and gear oil are used for lubrication and contain mineral oils and synthetic oils.

Brake Fluid

- Brake fluid contains several types of glycol-ether and anticorrosion additives for preventing metal components from corroding.



NOTICE

- Brake fluid contains ingredients that damage painted surfaces. If any comes in contact with the vehicle body, the paint may come off.

Power Steering Fluid

- Power steering fluid contain mineral oils and synthetic oils.

Window Washer Fluid

- Window washer fluid contains alcohol for freezing temperature control.

12 V Battery Electrolyte

- 12 V battery electrolyte contains dilute sulfuric acid.



WARNING

- Dilute sulfuric acid may cause irritation of the skin if contacted. Wear appropriate protective equipment such as rubber gloves and safety goggles when there is a risk of touching electrolyte.



NOTICE

- 12 V battery electrolyte contains ingredients that damage painted surfaces. If any comes in contact with the vehicle body, discoloration or other damage may occur.

Sub-battery Electrolyte

- A strong alkaline (pH 13.5) potassium hydroxide water solution is used as the sub-battery electrolyte. The electrolyte is soaked into non-woven fabric. However, if the sub-battery is damaged in any way, it may leak.



- Strong alkaline (pH 13.5) potassium hydroxide water solution is harmful to the human body. In cases where touching the electrolyte is unavoidable or there is a danger of it being touched, perform work wearing appropriate protective equipment such as rubber gloves and protective glasses.

Vehicle with High Voltage Battery

- There are 2 types of high voltage battery; the nickel-metal hydride type and the lithium ion type.

1. Nickel-metal hydride (Ni-MH) battery

- The Ni-MH battery contains a strong alkaline electrolyte (pH 13.5). The electrolyte is absorbed in the cell plates, but it may leak in case of damages to the high voltage battery. However, it would not be a large amount.
- Electrolyte leakage from the HV battery pack is unlikely considering the battery construction and the amount of electrolyte inside the module.
- Any spillage would not warrant a declaration as a hazardous material incident.



- Strong alkaline electrolyte (pH 13.5) is harmful to the human body. To avoid injury by coming in contact with the electrolyte, wear appropriate protective equipment such as rubber gloves and safety goggles when there is a risk of touching electrolyte.

2. Lithium ion (Li-ion) battery

- The Li-ion battery electrolyte, mainly consisted of carbonate ester, is a flammable organic electrolyte. The electrolyte is absorbed into the electrodes and the separators. It may leak in case of damages to the high voltage battery, but it would not be a large amount.
- Electrolyte will quickly evaporate if leaked from the battery cell.



- The flammable organic electrolyte which primarily contains carbonate ester is harmful to the human body. In case of contact with the electrolyte, it may irritate the eyes, nose, throat and skin. In case of contact with the smoke or vapor from leaked electrolyte or a burning battery, it may irritate the eyes, nose or throat. To avoid injury caused by coming in contact with the electrolyte or the vapor, wear appropriate protective equipment such as rubber gloves, safety goggles, protective mask or SCBA when there is a risk of touching electrolyte.
- If the electrolyte is spilled, keep it away from fire and ensure the area is well ventilated. Absorb the electrolyte with a piece of cloth or equivalent absorbent material, and keep it in an airtight container for proper disposal.

Vehicle with Solar Battery

- A strong alkaline (pH 13.5) potassium hydroxide water solution is used as the solar battery electrolyte. The electrolyte is soaked into non-woven fabric. However, if the solar battery is damaged in any way, it may leak. However, there is no risk of a mass leak.
- Electrolyte leakage from the solar battery is unlikely due to its construction and the amount of available electrolyte contained within the Ni-MH modules. Any spillage would not warrant a declaration as a hazardous material incident.



- Strong alkaline electrolyte (pH 13.5) is harmful to the human body. To avoid injury by coming in contact with the electrolyte, wear appropriate protective equipment such as rubber gloves and safety goggles when there is a risk of touching electrolyte.

Vehicle with Urea Solution

- Urea solution equipped vehicles have a urea tank that stores urea solution.
- The urea solution is a harmless noncombustible liquid. However, if the urea solution is heated due to a fire, etc., it breaks down and may emit a harmful gas.



- If you come in contact with smoke or vapor from a burning urea tank, it may irritate the eyes, nose or throat. To avoid injury by coming in contact with the smoke or vapor from a burning urea tank, wear appropriate protective equipment such as rubber gloves, safety goggles, a protective mask or SCBA when there is a risk of contacting the smoke or vapor.

Vehicle with Hydrogen Gas

- The FC stack coolant used to cool the FC stack, etc. is colorless and transparent and contains ethylene glycol in order to lower the freezing point.

Gas Leaks

- There are various types of gas used in vehicles. For example, there is nitrogen (N₂) gas used in gas filled dampers, refrigerant gas for air conditioners, and CNG, LPG and hydrogen gas.

Nitrogen (N₂) Gas

- Nitrogen (N₂) is used in gas filled dampers.
- The gas is colorless, odorless, and harmless.

Refrigerant Gas

- The refrigerant gas used in air conditioner is R-134a or R-1234yf.
- The gas is containing carbon and fluorine.
- The gas is colorless, odorless, and harmless.

Vehicle with CNG

- Compressed Natural Gas (CNG) is a flammable gas that mainly contains methane.
- The gas is colorless and harmless.
- The gas is infused with a smell so that a leak can be quickly detected.



- If the sound of natural gas leaking (a loud hissing sound) can be heard when working on the vehicle, or if the smell of natural gas is present, immediately step away from the vehicle as there is a chance that the natural gas may ignite.

Vehicle with LPG

- Liquefied Petroleum Gas (LPG) is a flammable gas that mainly contains propane and butane.
- The gas is colorless and harmless.
- The gas is infused with a smell so that a leak can be quickly detected.



- If the sound of LPG leaking (a loud hissing sound) can be heard when working on the vehicle, or if the smell of LPG is present, immediately step away from the vehicle as there is a chance that the LPG may ignite.

Vehicle with Hydrogen Gas

- Hydrogen gas is a flammable gas.
- The gas is colorless, odorless, and harmless.



- If the sound of hydrogen leaking (a loud hissing sound) can be heard when working on the vehicle, or if the hydrogen concentration around the vehicle exceeds 4% when measured with a hydrogen concentration detector, immediately step away from the vehicle as there is a chance that the hydrogen gas may ignite.

Damaged Vehicle Handling Key Points

- Points to be noted when handling damaged vehicles are provided in this section.

Towing Damaged Vehicle

- Loading a vehicle onto a car carrier (flat bed trailer) is the preferred method of towing.
- Only the FF (Front-engine Front-wheel drive) vehicles are available to tow with rear wheels on the ground.
- If towing the vehicle with all four wheels on the ground is unavoidable, release the parking lock, move the shift lever to neutral (N), and unlock the steering wheel first. The vehicle can then be towed at a low speed (below 30 km/h) for a distance of up to 80 km in a forward direction. (*Except vehicles with a high voltage battery. See page 95 for details.)
- Refer to the illustrations on the following page for correct and incorrect methods of towing FF (Front-engine Front-wheel drive), FR (Front-engine Rear-wheel drive), MR (Mid-engine Rear-wheel drive) and 4WD (Four Wheel Drive) vehicles.



- When towing a vehicle with all four wheels on the ground, make sure the vehicle is in "Ignition-On" mode. If in "Off" mode, the steering wheel may lock, making the steering inoperative.



- Exceeding the towing distance or speed limit when towing a vehicle with all four wheels on the ground or towing a vehicle with the vehicle facing backwards, may damage the transmission or transaxle.
- When the vehicle is equipped with a stop and start system, towing the vehicle with all four wheels on the ground may damage the system.

Parking Lock

- The parking lock can be released by moving the shift lever from park (P) to neutral (N) while pushing and holding the "lock release button" on the shift gate.

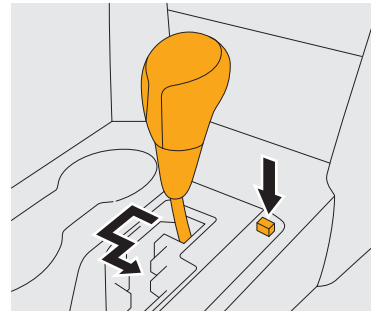

- The parking lock for vehicles equipped electric shift switches (vehicles with a P position switch) cannot be released while the 12 V negative (-) battery terminal is disconnected. When moving the vehicle, use a jack, etc.

Steering Wheel Lock

- The steering wheel can be unlocked by pushing the engine/power switch until in “Ignition-On” mode, or turning the ignition switch to any position other than “LOCK”.
- When it is difficult to release the lock, turn the steering wheel in either direction while pushing the engine/power switch or turning the key.

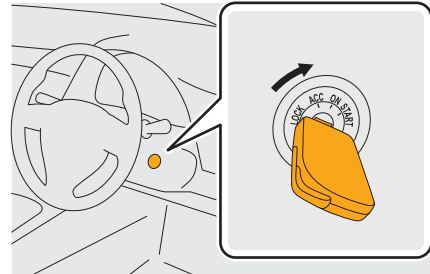

- When a vehicle is equipped with the electrical key transmitter system, the steering wheel cannot be unlocked if the negative (-) terminal of the 12 V battery is disconnected. Use wheel dollies or similar equipment when moving the vehicle.

Precautions for FF (Front-engine Front-wheel drive) vehicle

- Tow the vehicle with the front wheels or all four wheels off the ground.

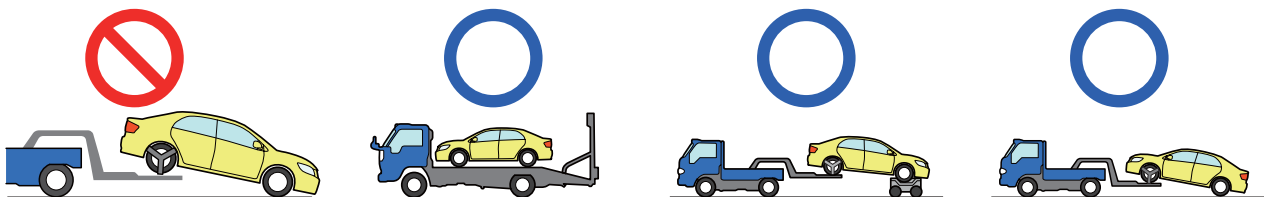

Precautions for FR (Front-engine Rear-wheel drive), MR (Mid-engine Rear-wheel drive) and 4WD (Four Wheel Drive) vehicles

- Tow the vehicle with all four wheels off the ground.

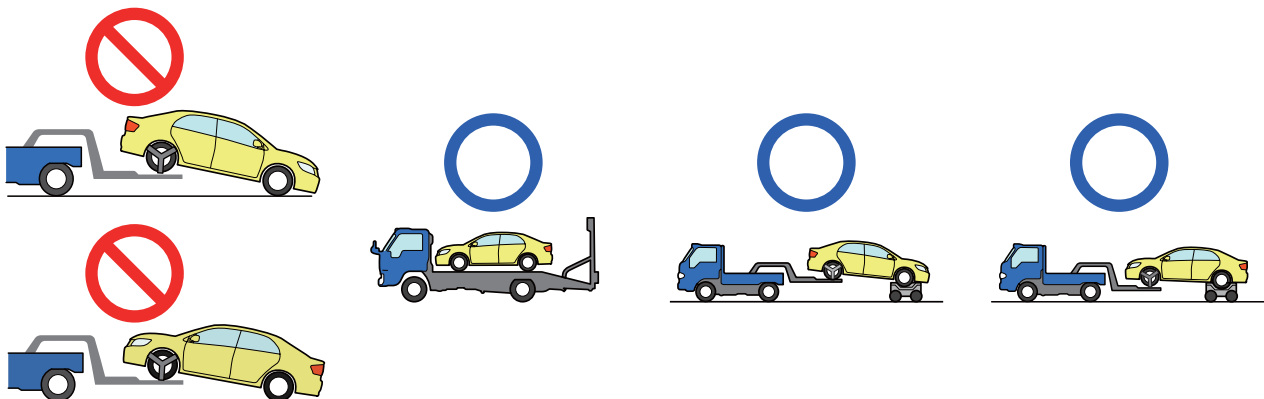

Vehicle with High Voltage Battery

- Make sure the negative (-) terminal of the 12 V battery is disconnected, then load the vehicle onto a car carrier (flat bed trailer).
- If towing the vehicle with all four wheels on the ground is unavoidable, only tow it for a short distance (such as to a car carrier (flat bed trailer)) in a forward direction at a low speed (below 30 km/h (18 mph)).
- Refer to the above illustrations for correct and incorrect methods of towing FF, FR and 4WD vehicles.



WARNING

- Hybrid vehicles (HV), plug-in hybrid vehicles (PHV), electric vehicles (EV) and fuel cell vehicles (FCV) are equipped with a high voltage electrical system (over 144 V, up to 650 V).
- To prevent serious injury or death from severe burns or electric shock, avoid touching, cutting, or breaching any orange high voltage power cable or high voltage component. Wear appropriate protective equipment such as insulated gloves when there is a risk of touching high voltage power cables or high voltage components.



NOTICE

- If hybrid vehicles (HV), plug-in hybrid vehicles (PHV), electric vehicles (EV) or fuel cell vehicles (FCV) are towed with the drive wheels on the ground, it could have adverse effects on the high voltage system and damage it.

Storing a Damaged Vehicle

- Drain gasoline, oil and other fluids, then disconnect the negative (-) terminal of the 12 V battery before storing a damaged vehicle.

Submerged Vehicle

- In addition to the normal procedures, remove the water from the vehicle.



NOTICE

- A vehicle that has been submerged in water poses a threat of vehicle fire after some time for possible short circuits due to electrical corrosion (wiring and circuit boards to corrode in an electrochemical reaction with water). To store a vehicle that has been submerged in water, choose a well-ventilated place at least 15 meters (49.2 feet) away from other objects.
- To prevent a vehicle fire, avoid turning the ignition switch or power switch of a submerged vehicle to ACC or ON.

Vehicle with High Voltage Battery

- In addition to the normal procedures, remove the service plug from the high voltage battery before storing a damaged vehicle.



WARNING

- The service plug is a high voltage component. Touching it without appropriate protective equipment may result in serious injury or death from severe burns and electric shock from the high voltage electrical system. Wear appropriate protective equipment such as insulated gloves when touching the service plug.
- The high voltage battery is still charged with high voltage electricity even after the vehicle is shut off, disabled (see page 72) and the service plug is removed from the high voltage battery.
- To prevent serious injury or death from severe burns or electric shock, avoid touching, cutting, or breaching any orange high voltage power cable or high voltage component. Wear appropriate protective equipment such as insulated gloves when there is a risk of touching high voltage power cables or high voltage components.
- When the person(s) in charge of handling the damaged vehicle is away from the vehicle, other person(s) may accidentally touch the vehicle and be electrocuted, resulting in severe injury or death. To avoid this danger, display a "HIGH VOLTAGE DO NOT TOUCH" sign to warn others (print and use page 25 of this guide).



NOTICE

- A high voltage battery may cause a vehicle fire after some time for possible short circuits inside due to the impact of collision or electrical corrosion. To store a vehicle equipped with a high voltage battery, choose a well-ventilated place at least 15 meters (49.2 feet) away from other objects.

Vehicle with Hydrogen Gas

- In addition to the normal procedures, remove the service plug from the FC stack before storing a damaged vehicle.



- The service plug is a high voltage component. Touching it without appropriate protective equipment may result in serious injury or death from severe burns and electric shock from the high voltage electrical system. Wear appropriate protective equipment such as insulated gloves when touching the service plug.
- To prevent serious injury or death from severe burns or electric shock, avoid touching, cutting, or breaching any orange high voltage power cable or high voltage component. Wear appropriate protective equipment such as insulated gloves when there is a risk of touching high voltage power cables or high voltage components.
- When the person(s) in charge of handling the damaged vehicle are away from the vehicle and someone else accidentally approaches or touches the vehicle, death or serious injury may occur due to electrocution, a rupture, an explosion or fire. To avoid this danger, display “HIGH VOLTAGE DO NOT TOUCH” and “HIGH-PRESSURE GAS DO NOT TOUCH” signs to warn others (print and use page 25 and 36 of this guide).



- Vehicles that are equipped with hydrogen gas may leak due to damage incurred during an accident. The remaining hydrogen may ignite causing a fire or explosion. Therefore, when storing a vehicle equipped with hydrogen gas, place it in a well ventilated area 15 meters or more away from other items and leave the windows or doors open.

Vehicle with Sub-battery



- Due to the impact during the collision and electrolytic corrosion of the sub-battery, a short circuit may occur internally causing a fire to occur after a certain amount of time elapses. When storing a vehicle equipped with a sub-battery, place it in a well ventilated area 15 meters or more away from other items.

